

HQ-140-X COMMUNICATIONS RECEIVER

TECHNICAL DESCRIPTION &
OPERATING INSTRUCTIONS

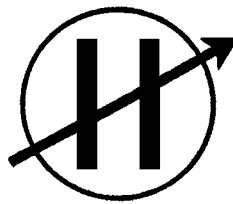

HAMMARLUND

460 West 34th Street : : : : New York 1, N. Y.

ERRATA

For all HQ-140-X receivers No. 299 and below the following change should be made on the schematic diagram, Fig. 7.

The Line running up from R48 is connected to the top instead of the bottom of the S4 switch.

For all HQ-140-X receivers No. 849 and below make the following change:

Resistor R35 is 820K ohms (Hammarlund Part No. 19309-103) instead of 180K ohms on the schematic diagram, Fig. 7, and in the Parts List, page 19.

For all receivers 1099 and below C25 is 4 mmf.

For all receivers No. 1494 and below make the following change:

Item C68 is a ceramic trimmer, NPO, 1.5-7 mmf and carries part number 23059.



Fig. 1—The HQ-140-X Receiver.

INTRODUCTION

The Hammarlund HQ-140-X is a modern, general purpose, super-heterodyne communications receiver designed to maintain high performance characteristics for many years without adjustment. The standard cabinet model has a self-contained stabilized power supply operating from a 50-60 cps, 105-125 volt AC source.

Frequency coverage is continuously tunable from 540 Kc to 31 Mc (555 to 9.7 meters) with adequate selectivity to separate crowded signals. Full use of the receiver's high sensitivity is available for reception of even the weakest stations because of inherently high signal-to-noise ratio and the superior Hammarlund noise limiter. The special patented Hammarlund crystal filter provides extreme selectivity for the high attenuation of closely adjacent interfering signals.

Band spread tuning is available on the four higher frequency ranges, with direct calibration for the 80, 40, 20, 15, and 10 meter amateur bands. Calibration charts for other ranges may be easily made for use with the arbitrary band-spread logging scale.

While this receiver was designed primarily for communications use, good fidelity of music and voice reproduction in both the standard and short wave broadcast bands is provided. Power hum is negligible. Either headphones or loudspeaker may be used. Automatic volume control aids in keeping music and voice reception at the desired level.

When you are interested in receiving telegraph or code signals, you will find that the HQ-140-X incorporates an unusually stable beat frequency oscillator. An "S" Meter enables you to obtain accurate reports on received phone signals while the Send-Receive switch and relay connections permit associated transmitter operation without interference.

Large, comfortable and carefully positioned controls make the HQ-140-X a truly professional-type receiver, the ideal instrument for operating in today's crowded short-wave bands.

INSTALLATION AND OPERATION

Unpack the receiver carefully. Make sure that the fuse, tubes, associated tube shields and pilot lamps are in place. Tubes V4, V5, V6, V8, V9, V10, and V11 are not shielded.

Connect the permanent magnet dynamic speaker to the two terminals marked SPEAKER on the rear of the receiver chassis. For best performance do not place speaker on top of receiver cabinet. The antenna may then be connected as described under ANTENNA.

Basically, all that is necessary to operate a radio receiver are the tuning and volume controls. The additional knobs and switches found on a professional-type receiver such as the HQ-140-X control functions which greatly improve operating performance.

The receiver "ON-OFF" switch is on the AUDIO GAIN control. If you are unfamiliar with the type of power available, check with the local power company before plugging in receiver. Turn on the receiver by advancing the AUDIO GAIN. Check to see that the pilot lamps light and tubes warm up.

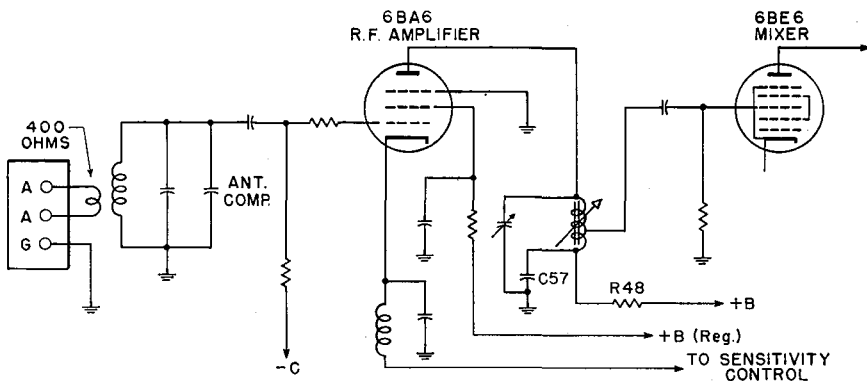

Fig. 2—Tuned RF Amplifier and Mixer.

While the tubes are heating, set the TUNING RANGE switch in the .54-1.32 position, MAN-AVC-BFO on AVC (automatic volume control), CRYSTAL SELECTIVITY on OFF, STANDBY-RECEIVE on RECEIVE, and SENSITIVITY on "10". Tune in the broadcast stations by using the MAIN TUNING dial and AUDIO GAIN control.

For accurate tuning watch the "S" meter. Adjust the MAIN TUNING dial for maximum meter reading for the station to which you are listening.

The ANTENNA compensator knob, the final adjustment, also should be set for greatest meter deflection.

When automatic volume control is not desired, the MAN-AVC-BFO switch can be set on MAN (Manual), the AUDIO GAIN control turned fully clockwise, and the SENSITIVITY control employed to provide the desired volume. When headphones are plugged into the jack in the lower right hand corner of the panel, the speaker is disconnected. On the rear of the chassis are two pin jacks marked RELAY which can be connected to the send-receive relay of the transmitter for break-in operation. With the STANDBY-RECEIVE switch in STANDBY, the receiver is silent but ready for instant use.

The BFO (Beat Frequency Oscillator) control provides a wide choice of tones for CW code operation. Turning the MAN-AVC-BFO switch to BFO disconnects the automatic volume control, and the SENSITIVITY control must then be employed. It is often a great help to use the LIMITER in short wave reception.

The PHASING control normally is set at the arrow in the center of its scale, but may be adjusted to cut out interference from stations on either side of the signal. With the CRYSTAL SELECTIVITY switch the operator can choose the degree of selectivity that provides the greatest fidelity with minimum interference. The first three positions are for phone reception and the fifth and sixth for single signal code reception in extremely crowded bands.

Set controls as follows for initial operation:

| <i>CONTROL</i> | <i>for PHONE</i> | <i>for CW or CODE</i> |
|---------------------|----------------------|---------------------------|
| MAN-AVC-BFO | AVC | BFO |
| CRYSTAL SELECTIVITY | OFF | OFF |
| CRYSTAL PHASING | At Arrow | At Arrow |
| CW TONE | Inoperative | ± 2 |
| STANDBY-RECEIVE | RECEIVE | RECEIVE |
| LIMITER | As required | As required |
| ANTENNA | To Peak Signal | To Peak Signal |
| AUDIO GAIN | Adjust | 10 |
| SENSITIVITY | 10 | Adjust |

TUNING RANGES

| <i>Band</i> | <i>Frequency</i> | <i>Meters</i> |
|-------------|------------------|--------------------|
| | | <i>Wave Length</i> |
| 1 | .540—1.32 Mc | 555 —227 |
| 2 | 1.32—3.2 Mc | 227 —93.7 |
| 3 | 3.2 —5.7 Mc | 93.7—52.6 |
| 4 | 5.7 —10 Mc | 52.6—30.0 |
| 5 | 10 —18 Mc | 30.0—16.7 |
| 6 | 18 —31 Mc | 16.7—9.7 |

TUNING PROCEDURE

To tune in a standard broadcast station, it is merely necessary to tune the MAIN TUNING dial to the desired frequency. The BAND SPREAD dial is inoperative on the first two ranges.

For reception of short wave stations with the MAIN TUNING dial only, it is necessary to set the BAND SPREAD dial to 100 in order to attain a calibration accuracy of 1% or better.

The BAND SPREAD dial is calibrated directly for the 80, 40, 20, 15, and 10 meter amateur bands. To make use of this feature, set the MAIN TUNING dial at the high frequency end of the desired amateur band. The BAND SPREAD dial then may be tuned over the range selected. For a higher degree of accuracy the BAND SPREAD dial may be set to the exact frequency of a known signal and the MAIN TUNING dial carefully tuned for maximum signal. It is no longer necessary to touch the MAIN TUNING dial, and the BAND SPREAD calibration will hold.

A 0-100 arbitrary logging scale is also provided for band-spread tuning of any desired ranges which are not directly calibrated. Again the MAIN TUNING dial is set at the high end of the selected range. Turning the BAND SPREAD dial from 100 to 0 tunes the receiver progressively lower in frequency.

The following table indicates the approximate frequency range covered by the BAND SPREAD dial at various settings of the MAIN TUNING dial, for each of the four higher frequency bands of the receiver.

| <i>Band</i> | <i>Low End</i> | <i>Middle</i> | <i>High End</i> |
|-------------|----------------|---------------|-----------------|
| 3.2—5.7 Mc | 0.4 Mc | 0.7 Mc | 1.25 Mc |
| 5.7—10 Mc | 0.2 Mc | 0.5 Mc | 0.9 Mc |
| 10 —18 Mc | 0.2 Mc | 0.5 Mc | 0.9 Mc |
| 18 —31 Mc | 0.6 Mc | 1.2 Mc | 2.2 Mc |

DESIGN

| <i>Symbol</i> | <i>Type</i> | <i>Tube Complement</i> | <i>Function</i> |
|---------------|-------------|------------------------|---------------------------------|
| V1 | 6C4 | Triode | Oscillator |
| V2 | 6BA6 | Remote Cutoff Pentode | RF Amplifier |
| V3 | 6BE6 | Pentagrid Converter | Mixer |
| V4 | 6BA6 | Remote Cutoff Pentode | 1st IF Amplifier |
| V5 | 6BA6 | Remote Cutoff Pentode | 2nd IF Amplifier |
| V6 | 6BA6 | Remote Cutoff Pentode | 3rd IF Amplifier |
| V7 | 6AL5 | Twin Diode | Detector, AVC; Noise Limiter |
| V8 | 12AU7 | Twin Triode | 1st AF Amplifier; BFO |
| V9 | 6V6GT/G | Beam Power | Audio Power Output |
| V10 | 0C3/VR105 | Voltage Regulator | Voltage Regulator |
| V11 | 5U4G | Full Wave Rectifier | Rectifier |

PRE-SELECTION

The antenna input coupling and RF amplifier stage provide the necessary pre-selection and gain for high performance and rejection of undesired signals. The high signal level at the mixer grid, V3, contributes to a favorable signal to noise ratio.

Both grid and plate circuits of the RF stage are tuned; individual tuning coils are selected for each band.

The antenna compensating capacitor, adjustable from the front panel, permits the receiver to be resonated for optimum performance with the antenna in use.

CONVERTER STAGE

A high degree of oscillator stability is attained by the use of a separate mixer (6BE6), V3, and an independent oscillator (6C4), V1.

The output signal from RF amplifier, V2, is heterodyned with the output of the local high frequency oscillator, V1, and electronically combined within the mixer tube, V3. On the four lower frequency ranges the local oscillator is 455 Kc above the signal frequency. On the two highest ranges the oscillator is 455 Kc below the signal frequency.

Low-loss tube sockets, ceramic band switches, temperature compensating capacitors, zero temperature coefficient ceramic trimmers, and a bi-metallic compensating plate all contribute to oscillator stability. Additional frequency stability is attained by applying regulated voltage to the oscillator plate and by the rugged construction of the entire oscillator section assembly.

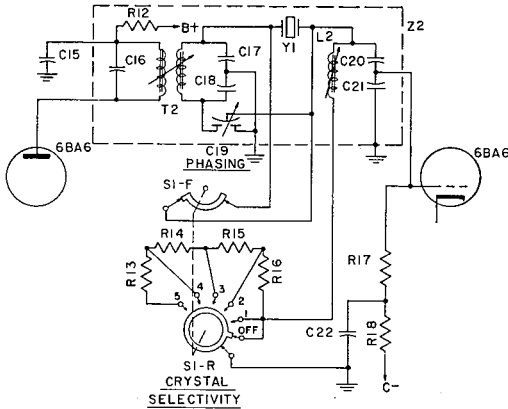

Fig. 3—Crystal Filter Circuit.

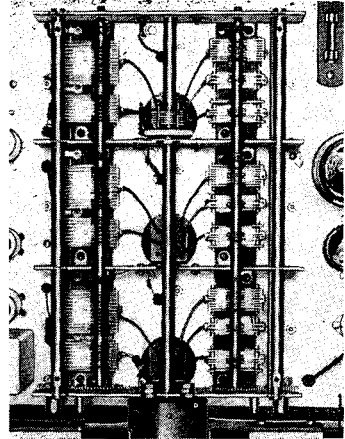

Fig. 4—H. F. Tuning Assembly.

CRYSTAL FILTER AND PHASING NETWORK

The patented Hammarlund 455 Kc crystal filter and phasing network is controlled from the HQ-140-X front panel. Its six-position SELECTIVITY switch includes an OFF position and five increasingly selective bandwidths.

Switch positions 1, 2, and 3 provide progressively sharper crystal selectivity for use in phone reception. Positions 4 and 5, the sharpest selectivity positions, are recommended for reliable CW or code reception. Highest fidelity is obtained in the OFF position, when the crystal filter is inoperative.

The phasing control may be set to highly attenuate interfering adjacent signals. With experienced operating technique the crystal filter offers distinct advantages under severe interference conditions.

IF AMPLIFIER

Nine tuned circuits, in three stages of IF amplification (V4, V5, and V6), contribute to sensitivity and selectivity. The gain per stage is purposely low in order to maintain stability. Iron core permeability-tuned transformers improve performance and add to the ease of adjustment. The intermediate frequency is 455 Kc, the RTMA standard.

AVC SYSTEM

Automatic Volume Control minimizes fading and signal strength variations by controlling the gain of the RF stage V2 and the IF stages V4 and V5. As a result, a comfortable and constant level of audio is maintained.

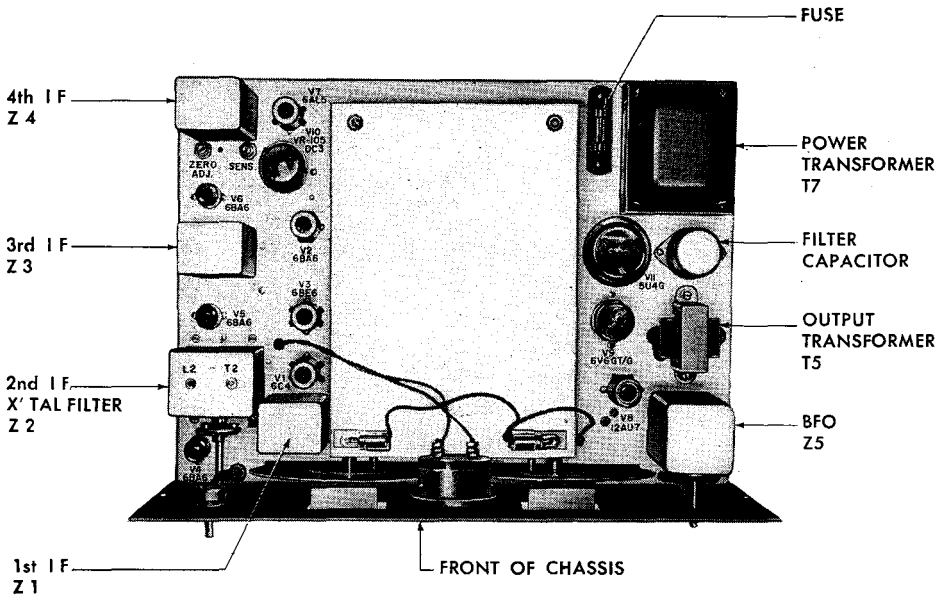

Fig. 5—Top view showing chassis layout.

The Automatic Volume Control is operative only when the MAN-AVC-BFO switch is in the AVC position. With AVC, greatest signal-to-noise ratio will result with the SENSITIVITY control set at maximum. It may be necessary to reduce sensitivity slightly for unusually strong signals.

“S” METER

The “S” or Tuning Meter is provided to assist in tuning and to give an indication of relative signal strength. Because the meter readings are proportional to AVC voltage, it is operative only when the MAN-AVC-BFO switch is in the AVC position.

The meter, which is calibrated to 20 db over S-9, is factory adjusted so that a signal input of approximately 50 microvolts gives a reading of S-9. Each “S” unit indicates a 6 db increase, equivalent to doubling signal strength.

Should meter re-adjustment be necessary:

1. Set front panel SENSITIVITY control to “10” and CRYSTAL SELECTIVITY to “OFF”.
2. With receiver off, mechanically zero pointer with a fine screw-driver.

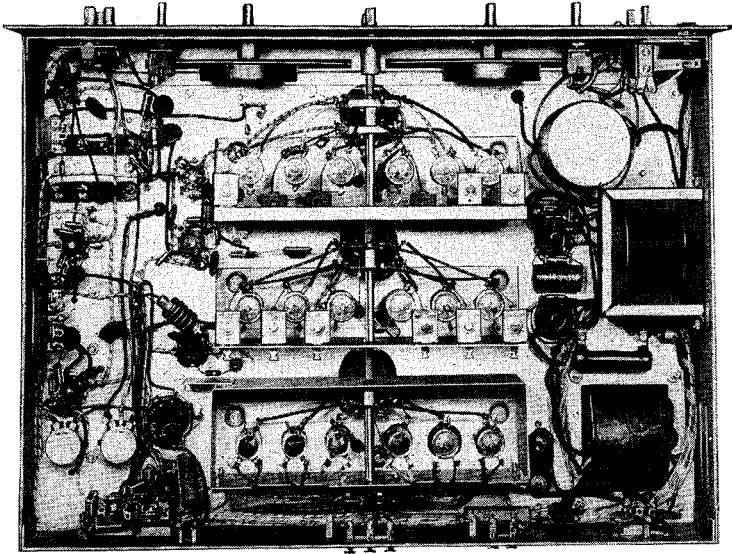

Fig. 6--Bottom view showing placement of parts.

3. With the AVC on and the 1st IF tube V4 removed, zero pointer with ZERO ADJ potentiometer R-19.
4. With AVC on and V4 replaced, adjust meter sensitivity with SENS potentiometer R-23.

SECOND DETECTOR AND NOISE LIMITER

One section of the 6AL5 tube V7 is used for the second detector and AVC system. This system produces a minimum of distortion.

The other half of V7 operates as a series, self adjusting noise limiter. It will reduce automobile ignition and other types of impulse noise to a minimum. Intelligibility is not affected by the noise limiter, although it may be switched off if desired.

BEAT FREQUENCY OSCILLATOR

The Beat Frequency Oscillator, which employs one section of the 12AU7 (V8), is designed to provide reception of CW or unmodulated code signals. The CW TONE control permits selection of the desired audio tone. Each calibration division represents approximately 1000 cycles.

The BFO is only operative when the MAN-AVC-BFO switch is in the BFO position.

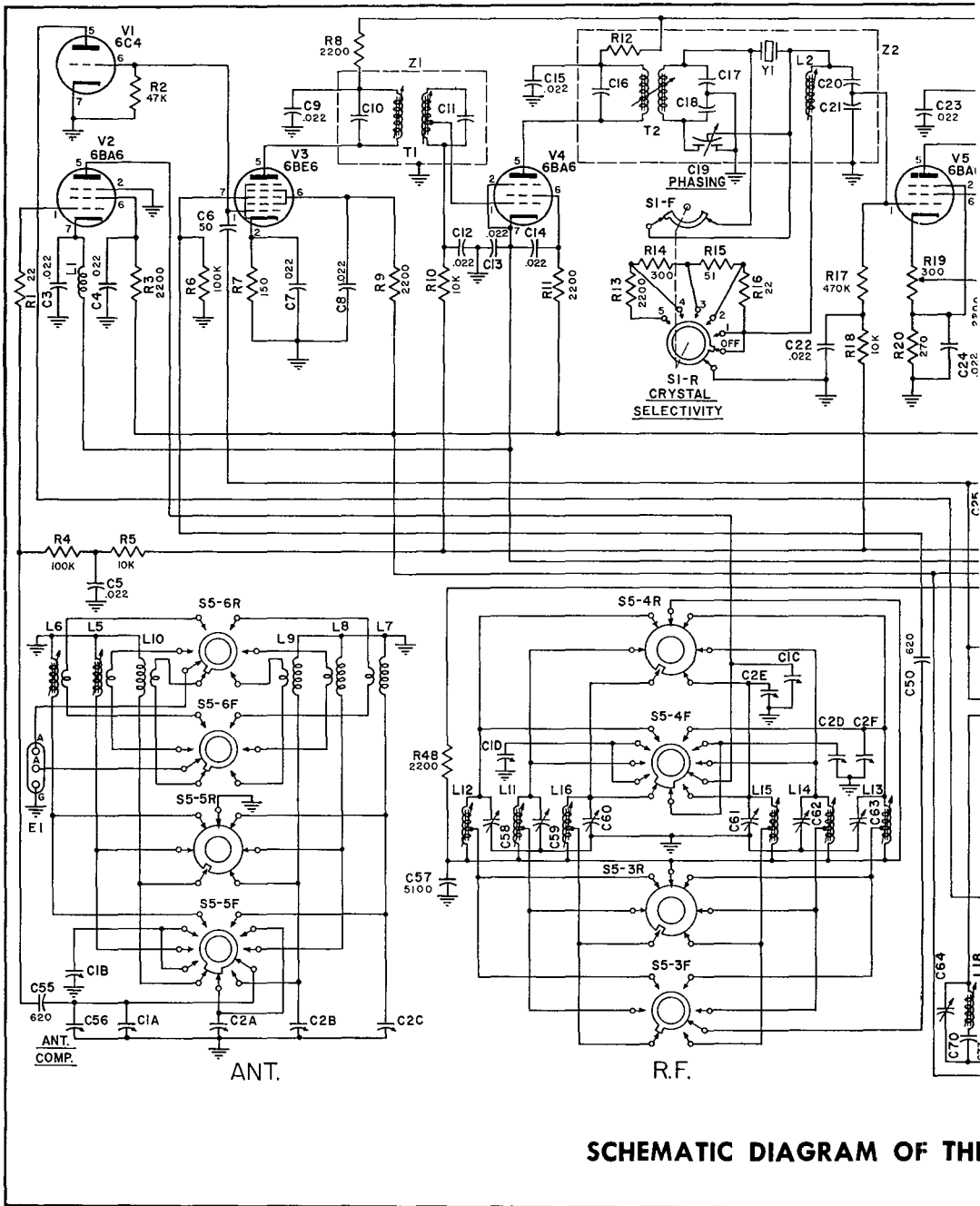

SCHEMATIC DIAGRAM OF THE

Fig. 7—Circuit diagram

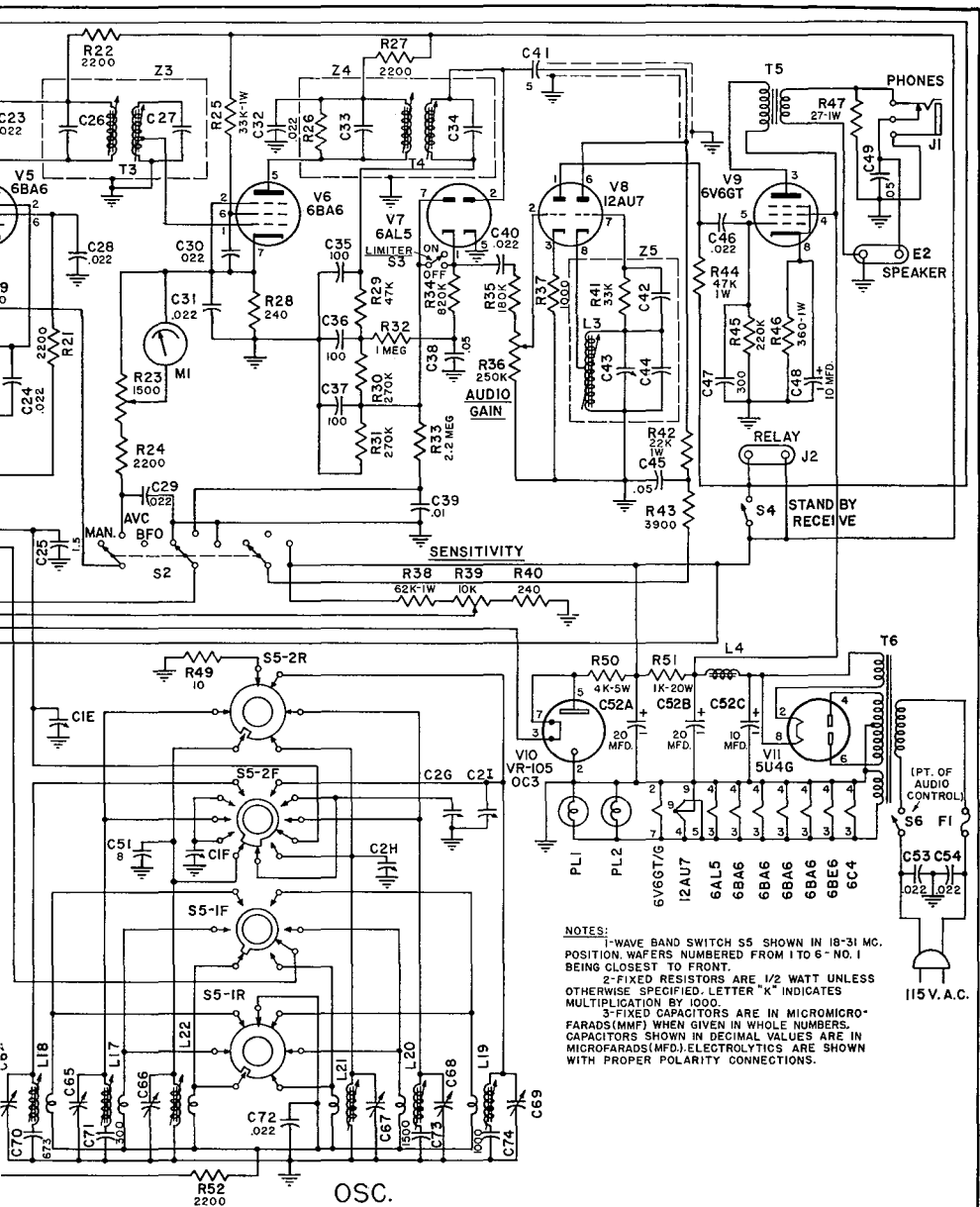

NOTES:
 1-WAVE BAND SWITCH S5 SHOWN IN 18-31 MC. POSITION, WAFERS NUMBERED FROM 1 TO 6 - NO. 1 BEING CLOSEST TO FRONT.
 2-FIXED RESISTORS ARE 1/2 WATT UNLESS OTHERWISE SPECIFIED. LETTER "K" INDICATES MULTIPLICATION BY 1000.
 3-FIXED CAPACITORS ARE IN MICROMICRO-FARADS (MMF) WHEN GIVEN IN WHOLE NUMBERS. CAPACITORS SHOWN IN DECIMAL VALUES ARE IN MICROFARADS (MFD). ELECTROLYTICS ARE SHOWN WITH PROPER POLARITY CONNECTIONS.

THE HQ-140-X RECEIVER

diagram.

AUDIO AMPLIFIER

The first audio stage is a resistance coupled voltage amplifier using the other section of the 12AU7 (V8). The audio output stage, a 6V6GT/G beam power amplifier (V9) provides an undistorted output of at least 2 watts.

The output transformer impedance is 6 ohms to match the voice coil of the Hammarlund or other suitable permanent magnet speaker. The phone jack is connected across the voice coil winding and silences the speaker when the phone plug is inserted.

POWER SUPPLY

The self-contained, stabilized power supply is designed with a large safety factor to insure reliable, trouble-free operation. Hum-free performance is provided by a two section filter. High voltage is supplied by the 5U4G rectifier, V11. The OC3/VR105 (V10) furnishes regulated voltage to the variable frequency oscillator V1 and the screen grid of V2, V3, V4, and V5.

ANTENNA

The HQ-140-X is designed for use with either a single wire or balanced type of antenna. A good match to most antenna systems will be obtained because of the receiver's input impedance, nominally 400 ohms, and its high sensitivity.

For general coverage an indoor wire of 20 to 50 feet will give surprisingly good reception. A long single wire outdoor antenna such as shown in Figure 8 will generally give entirely satisfactory performance. This wire may be 50 to 75 feet long.

For best reception the antenna should be isolated as much as possible from neighboring objects.

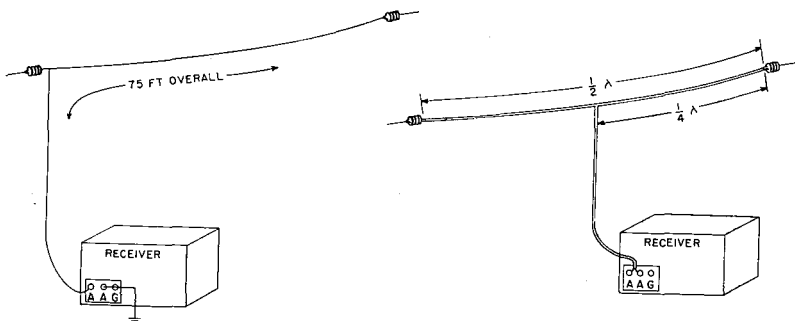

Fig. 8—Antenna suggestions.
(A) Single Wire. (B) 300 ohm folded di-pole.

Optimum performance on a particular amateur band or other narrow tuning range will be obtained by using a half-wave di-pole or folded di-pole fed with 300 ohm or suitable lead-in as shown in Figure 8B.

The length of the required di-pole may be calculated by the following formula:

$$\text{Length (feet)} = \frac{468}{\text{Freq. (Mc)}}$$

A good ground, although not absolutely necessary, will frequently aid in reception.

RE-ALIGNMENT PROCEDURE

A. Equipment necessary

1. Cathode-ray oscilloscope (externally synchronized by the signal generator.)
2. Frequency Modulated (swept) signal generator (fairly constant output.)
3. Output Meter.

B. IF Amplifier

The intermediate-frequency transformers are iron-core permeability-tuned, and resonated with fixed silver-mica capacitors. A high degree of stability results, which should make IF re-alignment unnecessary for a long time. Re-alignment should not be attempted without suitable equipment.

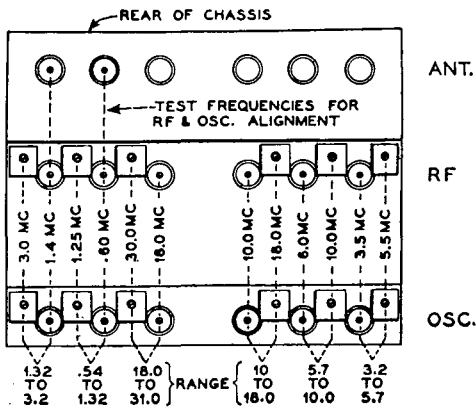

Fig. 9—Left: Diagram for tuning IF Amplifier, RF Stage and H. F. Oscillator.

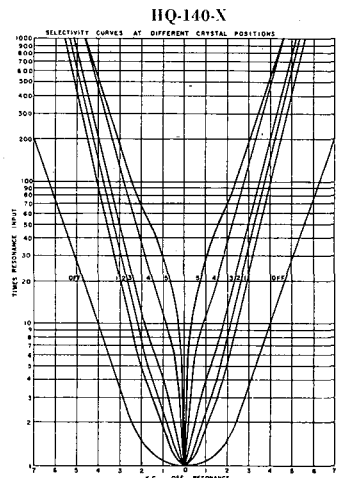

Fig. 10—Selectivity Curves.

The IF transformers must be tuned for symmetry and proper coincidence of the visible curves as well as for amplitude on the oscilloscope. This requires a stage-by-stage alignment, starting with the last IF transformer (Z4) and continuing back through the first IF transformer (Z1).

This is the procedure:

- (1) Set receiver as follows:

MAIN TUNING DIAL..... .54 Mc
Bandswitch (TUNING RANGE). .54—1.32 Mc
STANDBY-RECEIVE..... RECEIVE
LIMITER..... OFF
MAN-AVC-BFO..... MAN
CRYSTAL SELECTIVITY..... OFF

- (2) With the generator set at 455 Kc apply signal to the grid (pin No. 1) of the 3rd IF tube (V6). Adjust the two inductors of Z4 alternately to obtain maximum amplitude, symmetry, and pattern coincidence on the oscilloscope.
- (3) Apply the signal input lead to the grid (pin No. 1) of the 2nd IF tube (V5). Turn the two adjustment screws of Z3 to obtain a symmetrical, coinciding curve with as much amplitude as possible without disturbing the pattern.
- (4) Switch the signal input lead to the grid (pin No. 1) of the 1st IF tube (V4), and adjust the plate inductor (T2) of the crystal filter (Z2) for maximum amplitude at center of curve.
- (5) Apply the signal input to the grid (pin No. 7) of the 6BE6 mixer tube (V3). Adjust screws of 1st IF transformer (Z1) as in (3). This should result in a tall selectivity curve with a slightly flattened peak.
- (6) Turn CRYSTAL SELECTIVITY switch to position No. 1, set CRYSTAL PHASING pointer on arrow, and adjust the grid inductor (L2) of the crystal filter (Z2) for maximum amplitude and symmetry. Adjust signal input or receiver SENSITIVITY control as required to prevent overloading.
- (7) Switch to CRYSTAL SELECTIVITY position No 2, and if necessary, move PHASING CONTROL slightly from arrow to obtain identical images.
Adjust signal generator frequency to obtain coincidence of the images. If complete coincidence is not obtained, alternately make slight adjustments of the PHASING

CONTROL and the signal generator frequency, until images coincide.

After these last steps have determined the exact frequency of the Quartz crystal, the frequency setting of the signal generator should be left undisturbed.

- (8) Repeat carefully the complete IF alignment procedure (steps 1 through 7) for the crystal frequency.

C. *RF Amplifier*

The RF and oscillator stages have been carefully aligned against standard crystals at the factory and are designed to hold their adjustments over a long period of time. Re-alignment should not be attempted unless it is positive that re-adjustment is necessary.

As shown on the chart, Figure 9, the front row of adjustments control the H. F. oscillator frequency and consequently dial calibration.

The middle row of adjustments control RF alignment and the rear adjustments are for antenna alignment.

Here is the procedure:

1. Set controls as follows:

Receiver

| | |
|----------------------------|-------------|
| STANDBY-RECEIVE..... | RECEIVE |
| MAN-AVC-BFO..... | MAN |
| CRYSTAL SELECTIVITY..... | OFF |
| BAND SPREAD..... | 100 |
| Bandswitch (TUNING RANGE). | .54—1.32 Mc |
| MAIN TUNING..... | .60 Mc |

Signal Generator

| | |
|-----------------|--------|
| Frequency..... | .60 Mc |
| Modulation..... | Off |

Each band is adjusted for maximum response by changing the inductance at the low-frequency end and the capacitance at the high-frequency end. These adjustments mutually affect each other. If much change is made at one end of the band, the other end of the band must also be re-adjusted. This procedure is repeated until dial calibration coincides with frequency at both ends of the band.

At 30 Mc there is some interaction between the RF and oscillator sections. It is therefore necessary to rock the MAIN

TUNING dial back and forth while adjusting the trimmer capacitor, in order to avoid a false setting.

2. With signal generator connected to the receiver ANTENNA terminals, and output meter connected to the SPEAKER terminals, adjust L17 until maximum deflection is obtained on the meter.

3. Change signal generator frequency to 1.25 Mc as shown in Figure 9. Set MAIN TUNING dial on 1.25 Mc to correspond. Adjust trimmer capacitor C73 to tune in signal, and C69 for maximum response.

4. Set signal generator to 1.4 Mc, change to the 1.32—3.2 Mc Band, and set MAIN TUNING dial on 1.4 Mc. Adjust L18 until signal appears and L12 and L6 for maximum response.

5. Change signal generator to 3 Mc, and set MAIN TUNING dial to 3 Mc to correspond. Adjust C64 to tune in signal and C58 for maximum response.

In like manner this procedure is followed for each band and should be repeated until calibration and tracking are as desired.

MAINTENANCE

The HQ-140-X is designed to give years of trouble-free service without need for repairs. Tube failure is the most common source of trouble. The second most common cause of difficulty is component failure among small resistors and fixed capacitors.

The following chart, Figure 11, gives voltages between tube socket terminals and chassis. Below each voltage, in parenthesis, is shown the meter scale required for checking with a voltmeter having a sensitivity of 1000 ohm \bar{s} per volt or better. Slight variations from voltages indicated may be disregarded.

With the aid of the chart and the schematic diagram, defective components can usually be located. The parts list in the back of this manual gives values and Hammarlund part numbers.

Standard items may be purchased locally. Non-standard components are available on order from the factory.

A delicate communications receiver should be entrusted only to a qualified technician. Should difficulty be experienced, please write the company for advice or to arrange for factory service.

| | LINE VOLTAGE 117 V.A.C. SENSITIVITY AND AUDIO | | | | | | | | | | MAN-AVC-BFO SWITCH POSITION | |
|-------------------------|---|---------------|-------------|--------------------------|--------------------------|--------------------------|--------------------------------|------------------------------|------------------------------|--------------------------------|---------------------------------------|-------------------------------|
| | Limiter-off | | | Man. Position | | | Receive Position | | | | AVC | BFO |
| | RF 6BA6 | Mixer 6BE6 | OSC 6C4 | 1st IF AMP 6BA6 | 2nd IF AMP 6BA6 | 3rd IF AMP 6BA6 | Det. AVC Limiter 6AL6 | Out- put 6V6GT | Recti- fier 5U4G | Volt. Reg. OC3/ VR105 | 1st Audio $\frac{1}{2}$ 12A7 | BFO $\frac{1}{2}$ 12AU7 |
| Pin 1 to ground..... | ... | ... | 92 (300) | ... | ... | ... | -0.2 (12) | ... | ... | Tie Point 210 (300) | 75 (300) | |
| Pin 2 to ground..... | ... | 1.1 (3) | ... | 3.5 (6) | 1.5 (3) | 2.3 (3) | -0.4 (12) | ... | 298 (300) | ... | | |
| Pin 3 to ground..... | 6.2 A.C. | 6.2 A.C. | 6.2 A.C. | 6.2 A.C. | 6.2 A.C. | 6.2 A.C. | 6.2 A.C. | 256 (300) | ... | 106 (300) | 2.3 (3) | |
| Pin 4 to ground..... | ... | ... | ... | ... | ... | ... | ... | 273 (300) | 280 A.C. | ... | 6.2 A.C. | |
| Pin 5 to ground..... | 200 (300) | 205 (300) | 92 (300) | 203 (300) | 200 (300) | 192 (300) | ... | ... | Tie Point 273 (300) | 106 (300) | 6.2 A.C. | |
| Pin 6 to ground..... | 100 (300) | 92 (300) | ... | 100 (300) | 100 (300) | 110 (300) | ... | Tie Point 210 (300) | 280 A.C. | ... | | 75 (300) |
| Pin 7 to ground..... | 3.6 (6) | ... | ... | 3.5 (6) | 3.1 (6) | 2.3 (3) | -0.2 (12) | 6.2 A.C. | ... | 106 (300) | | -13 (60)† |
| Pin 8 to ground..... | ... | ... | ... | ... | ... | ... | ... | 14 (60) | 298 (300) | ... | | |

PARTS LIST HQ-140-X

| SCHEMATIC DESIGNATION | DESCRIPTION | HAMMARLUND PART No. |
|-----------------------|--|---------------------|
| | CAPACITORS | |
| C1, A-F | Main Tuning, variable..... (Part of 20840-G1) | |
| C2, A-I | Band Spread, variable..... (Part of 20840-G1) | |
| C3, 4, 5 | Ceramic disc, .022 μ f W.V.D.C..... | 23034-24 |
| C6 | Silver mica, 50 μ f 500 W.V.D.C..... | 23071-5 |
| C7, 8, 9 | Ceramic disc, .022 μ f W.V.D.C..... | 23034-24 |
| C10 | Silver mica, 240 μ f 500 W.V.D.C. (Part of Z1, I.F. transformer assembly *26121)... | 23071-56 |
| C11 | Silver mica, 260 μ f 500 W.V.D.C. (Part of Z1, I.F. transformer assembly *26121)... | 23003-112 |
| C12, 13, 14, 15 | Ceramic disc, .022 μ f W.V.D.C..... | 23034-24 |
| C16 | Silver mica, 220 μ f 500 W.V.D.C. (Part of Z2, Crystal Filter Assembly *26125)..... | 23071-55 |
| C17, 18 | Silver mica, 100 μ f 500 W.V.D.C. (Part of Z2, Crystal Filter Assembly *26125)..... | 23003-94 |
| C19 | Crystal phasing variable, (Part of Z2, Crystal Filter Assembly *26125)..... | 11776-G1 |
| C20 | Silver mica, 270 μ f 500 W.V.D.C. (Part of Z2, Crystal Filter Assembly *26125)..... | 23003-104 |
| C21 | Silver mica, 100 μ f 500 W.V.D.C. (Part of Z2, Crystal Filter Assembly *26125)..... | 23003-94 |
| C22, 23, 24 | Ceramic disc, .022 μ f W.V.D.C..... | 23034-24 |
| C25 | Ceramic, NPO 1.5 μ f 500 W.V.D.C..... | 23023-107 CK |
| C26 | Silver mica, 240 μ f 500 W.V.D.C. (Part of Z3, I.F. transformer assembly *26123)..... | 23071-56 |

PARTS LIST HQ-140-X—Cont.

| SCHEMATIC DESIGNATION | DESCRIPTION | HAMMARLUND PART No. |
|-----------------------------|--|------------------------|
| <i>CAPACITORS—Continued</i> | | |
| C27 | Silver mica, 260 μf 500 W.V.D.C. (Part of Z3, I.F. transformer assembly #26123) | 23003-112 |
| C28,29,30,31,32 | Ceramic disc, .022 μf W.V.D.C. | 23034-24 |
| C33, 34 | Silver mica, 95 μf 500 W.V.D.C. (Part of Z4, Final I.F. transformer assembly #26112) | 23071-62 |
| C35, 36, 37 | Mica, 100 μf 500 W.V.D.C. | 23001-48 |
| C38 | Paper tubular, .05 μf 600 W.V.D.C. | 23912-2 |
| C39 | Paper tubular, .01 μf 400 W.V.D.C. | 23912-23 |
| C40 | Ceramic disc, .022 μf W.V.D.C. | 23034-24 |
| C41 | Silver mica, 5 μf 500 W.V.D.C. | 23002-1 |
| C42 | Silver mica, 240 μf 500 W.V.D.C. (Part of Z5, B.F.O. Assembly #26105) | 23071-56 |
| C43 | B.F.O. variable, (Part of Z5, B.F.O. Assembly #26105) | 11735-G42 |
| C44 | Silver mica, 220 μf 500 W.V.D.C. (Part of Z5, B.F.O. Assembly #26105) | 23071-55 |
| C45 | Paper tubular, .05 μf 600 W.V.D.C. | 23912-2 |
| C46 | Ceramic disc, .022 μf W.V.D.C. | 23034-24 |
| C47 | Mica, 300 μf 500 W.V.D.C. | 23001-75 |
| C48 | Electrolytic, 10 μf 150 W.V.D.C. | 23073-71 |
| C49 | Paper tubular, .05 μf 600 W.V.D.C. | 23912-2 |
| C50 | Mica, 620 μf 500 W.V.D.C. (Part of R.F. Unit Assembly #26131) | 23005-86 |
| C51 | Ceramic, NPO 8 μf 500 W.V.D.C. (Part of H.F. Oscillator Unit Assembly #26143) | 23023-22 CH |
| C52 | Electrolytic, 10-500V, 20-450V, 20-450V | 15504-61 |
| C53, 54 | Ceramic disc, .022 μf | 23034-24 |
| C55 | Mica, 620 μf , 500 W.V.D.C. | 23005-86 |
| C56 | Antenna Compensator, variable (Part of Main Tuning Unit #20840-G1) | SA-617 |
| C57 | Mica, 5100 μf 500 W.V.D.C. | 23015-16B |
| C58, 59, 60 | Trimmer, mica 3-35 μf | 16089-2 |
| C61 | Trimmer, mica 1.5-9 μf | 16089-1 |
| C62 | Trimmer, mica 3-35 μf | 16089-2 |
| C63 | Trimmer, mica 1.5-9 μf | 16089-1 |
| C64, 65 | Trimmer, mica 3-35 μf | 16089-2 |
| C66, 67 | Trimmer, ceramic NPO 1.5-7 μf | 23059-1 |
| C68 | Trimmer, ceramic NPO 3-12 μf | 23059-2 |
| C69 | Trimmer, mica 1.5-9 μf | 16089-1 |
| C70 | Silver mica 673 μf 500 W.V.D.C. | 23004-2 |
| C71 | Silver mica 300 μf 500 W.V.D.C. | 23003-105 |
| C72 | Ceramic disc, .022 W.V.D.C. | 23034-24 |
| C73 | Mica, 1500 μf 500 W.V.D.C. | 23015-20 |
| C74 | Mica, 1000 μf 500 W.V.D.C. | 23015-40 |
| F1 | Fuse, 2 ampere type 3AG | 15928-7 |
| J1 | Phone jack | 6087 |
| J2 | Relay jack | 6142 |
| E1 | Antenna terminal strip | 6088 |
| E2 | Speaker terminal strip | 3843 |
| <i>COILS</i> | | |
| L1 | R.F. choke (CH-X) | 609-G1 |
| L2 | Crystal Filter grid coil, (Part of Z2, Crystal Filter Assembly #26125-G1) | 31068-G1 |
| L4 | Filter choke | 26111-1 |
| L5 | Antenna coil assembly .54—1.32 mc range | 26051-G1 |
| L6 | Antenna Coil Assembly 1.32—3.2 mc range | 26051-G2 |
| L7 | Antenna Coil 3.2—5.7 mc range | 6013 |
| L8 | Antenna Coil 5.7—10 mc range | 6016 |

PARTS LIST HQ-140-X—Cont.

| SCHEMATIC DESIGNATION | DESCRIPTION | HAMMARLUND PART No. |
|--------------------------|---|------------------------|
| <i>COILS—Continued</i> | | |
| L9 | Antenna Coil 10—18 mc range..... | 6019 |
| L10 | Antenna Coil 18—31 mc range..... | 6022 |
| L11 | R.F. Coil Assembly .54—1.32 mc range..... | 26047-G2 |
| L12 | R.F. Coil Assembly 1.32—3.2 mc range..... | 26047-G1 |
| L13 | R.F. Coil Assembly 3.2—5.7 mc range..... | 26047-G6 |
| L14 | R.F. Coil Assembly 5.7—10 mc range..... | 26047-G5 |
| L15 | R.F. Coil Assembly 10—18 mc range..... | 26047-G4 |
| L16 | R.F. Coil Assembly 18—31 mc range..... | 26047-G3 |
| L17 | H.F. Osc. Coil Assembly .54—1.32 mc range..... | 26030-G2 |
| L18 | H.F. Osc. Coil Assembly 1.32—3.2 mc range..... | 26030-G1 |
| L19 | H.F. Osc. Coil Assembly 3.2—5.7 mc range..... | 26030-G6 |
| L20 | H.F. Osc. Coil Assembly 5.7—10 mc range..... | 26030-G5 |
| L21 | H.F. Osc. Coil Assembly 10—18 mc range..... | 26030-G4 |
| L22 | H.F. Osc. Coil Assembly 18—31 mc range..... | 26030-G3 |
| M1 | Carrier Level ("S") meter..... | 26149-G1 |
| PL1, 2 | Pilot Lamp No. 47, 6.3 V., .15 amp..... | 16004-1 |
| <i>RESISTORS</i> | | |
| R1 | 22 Ohms $\frac{1}{2}$ W..... | 19309-9 |
| R2 | 47,000 Ohms, $\frac{1}{2}$ W..... | 19309-89 |
| R3 | 2,200 Ohms, $\frac{1}{2}$ W..... | 19309-57 |
| R4 | 100,000 Ohms, $\frac{1}{2}$ W..... | 19309-97 |
| R5 | 10,000 Ohms, $\frac{1}{2}$ W..... | 19309-73 |
| R6 | 100,000 Ohms, $\frac{1}{2}$ W..... | 19309-97 |
| R7 | 150 Ohms, $\frac{1}{2}$ W..... | 19309-259 |
| R8, 9 | 2,200 Ohms, $\frac{1}{2}$ W..... | 19309-57 |
| R10 | 10,000 Ohms, $\frac{1}{2}$ W..... | 19309-73 |
| R11 | 2,200 Ohms, $\frac{1}{2}$ W..... | 19309-57 |
| R12 | 2,200 Ohms, $\frac{1}{2}$ W..... | 19309-57 |
| | (Part of Z2, Crystal Filter Assembly #26125)..... | 19309-57 |
| R13 | 2,200 Ohms, $\frac{1}{2}$ W..... | 19309-57 |
| R14 | 300 Ohms, $\frac{1}{2}$ W..... | 19309-202 |
| R15 | 51 Ohms, $\frac{1}{2}$ W..... | 19309-193 |
| R16 | 22 Ohms, $\frac{1}{2}$ W..... | 19309-9 |
| R17 | 470,000 Ohms, $\frac{1}{2}$ W..... | 19309-113 |
| R18 | 10,000 Ohms, $\frac{1}{2}$ W..... | 19309-73 |
| R19 | Potentiometer, 300 Ohms..... | 15368-1 |
| R20 | 270 Ohms, $\frac{1}{2}$ W..... | 19309-262 |
| R21, 22 | 2,200 Ohms, $\frac{1}{2}$ W..... | 19309-57 |
| R23 | Potentiometer, 1500 Ohms..... | 15368-2 |
| R24 | 2,200 Ohms, $\frac{1}{2}$ W..... | 19309-57 |
| R25 | 33,000 Ohms, 1 W..... | 19310-293 |
| R26 | 47,000 Ohms, $\frac{1}{2}$ W..... | 19309-89 |
| | (Part of Z4, I.F. Transformer Assembly #26113)..... | 19309-57 |
| R27 | 2,200 Ohms, $\frac{1}{2}$ W..... | 19309-57 |
| R28 | 240 Ohms, $\frac{1}{2}$ W..... | 19309-201 |
| R29 | 47,000 Ohms, $\frac{1}{2}$ W..... | 19309-89 |
| R30, 31 | 270,000 Ohms, $\frac{1}{2}$ W..... | 19309-107 |
| R32 | 1 Meg Ohms, $\frac{1}{2}$ W..... | 19309-121 |
| R33 | 2.2 Meg Ohms, $\frac{1}{2}$ W..... | 19309-129 |
| R34 | 820,000 Ohms, $\frac{1}{2}$ W..... | 19309-119 |
| R35 | 180,000 Ohms, $\frac{1}{2}$ W..... | 19309-103 |
| R36 | Potentiometer 250,000 Ohms (switch attached)..... | 6095 |
| R37 | 1,000 Ohms, $\frac{1}{2}$ W..... | 19309-49 |
| R38 | 62,000 Ohms, 1 W..... | 19310-231 |
| R39 | Potentiometer, 10,000 Ohms..... | 15367-1 |
| R40 | 240 Ohms, $\frac{1}{2}$ W..... | 19309-201 |
| R41 | 33,000 Ohms, $\frac{1}{2}$ W..... | 19309-85 |
| | (Part of Z5, B.F.O. Assembly #26107)..... | 19309-85 |

PARTS LIST HQ-140-X—Cont.

| SCHEMATIC DESIGNATION | DESCRIPTION | HAMMARLUND PART No. |
|--------------------------|--|------------------------|
| | <i>RESISTORS—Continued</i> | |
| R42 | 22,000 Ohms, 1 W..... | 19310-81 |
| R43 | 3,900 Ohms, 1/2 W. (Part of B.F.O. Bracket Assembly #26029-G2)..... | 19309-63 |
| R44 | 47,000 Ohms, 1 W..... | 19310-89 |
| R45 | 220,000 Ohms, 1/2 W..... | 19309-105 |
| R46 | 360 Ohms, 1 W..... | 19310-211 |
| R47 | 27 Ohms, 1 W..... | 19310-11 |
| R48 | 2,200 Ohms, 1/2 W. (Part of R.F. Unit Assembly #26137)..... | 19309-57 |
| R49 | 10 Ohms, 1/2 W. (Part of H.F. Osc. Assembly #26143)..... | 19309-1 |
| R50 | 4,000 Ohms, 5 W..... | 19380-47 |
| R51 | 1,000 Ohms, 20 W..... | 19435-19 |
| R52 | 2,200 Ohms, 1/2 W. (Part of H.F. Osc. Assembly #26143)..... | 19309-57 |
| | <i>SWITCHES</i> | |
| S1, F, R, | Crystal Selectivity Assembly | |
| S2 | MAN-AVC-BFO..... | 26155-1 |
| S3 | Limiter..... | 15864-2 |
| S4 | Standby-Receive..... | 15864-2 |
| S5-1F, R | H.F. Osc. plate..... | 6331 |
| S5-2F, R | H.F. Osc. grid..... | 6332 |
| S5-3F, R | Detector grid tap..... | 6064 |
| S5-4F, R | R.F. plate..... | 6063 |
| S5-5F, R | R.F. grid..... | 6063 |
| S5-6F, R | Antenna..... | 6062 |
| S6 | Power..... (Part of R36, Potentiometer #6095) | |
| | <i>TRANSFORMERS AND IMPEDANCE ASSEMBLIES</i> | |
| T5 | Audio Output Transformer..... | 26110-1 |
| T6 | Power Transformer..... | 26109-1 |
| Y | Crystal, 455 Kc..... | 6338-1 |
| Z1 | 1st I.F. Assembly, includes C10, C11, and T1..... | 26121-G1 |
| Z2 | Crystal Filter Assembly (2nd I.F.), includes C16, C17, C18, C19, C20, C21, L2, R12, T2, and Y1..... | 26125-G1 |
| Z3 | 3rd I.F. Assembly, includes C26, C27, and T3..... | 26123-G1 |
| Z4 | Final I.F. Assembly, includes C33, C34, R26, and T4..... | 26112-G1 |
| Z5 | B.F.O. Assembly includes C42, C43, C44, L3, and R41..... | 26107-G1 |