

GERNSBACK'S EDUCATIONAL LIBRARY No 4

# ALL ABOUT AERIALS

**10**  
CENTS

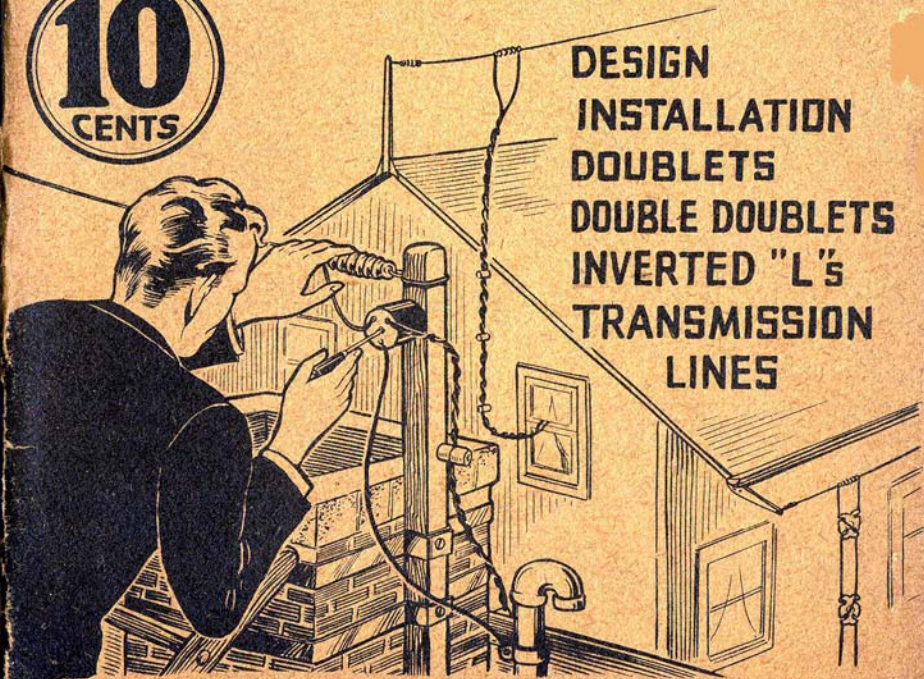

DESIGN  
INSTALLATION  
DOUBLET  
DOUBLE DOUBLET  
INVERTED "L"  
TRANSMISSION  
LINES

# ALL ABOUT AERIALS

## Part I — Receiving Antennas

NOTE: Refer to Glossary at end of book for definitions of technical terms used in the text.

**T**HE function of an aerial is to intercept the radio waves which sweep across it, and convey them (in the form of *radio frequency currents*) to the receiver. A transmitting station radiates many *kilowatts* of power into the air but, by the time this energy reaches your aerial, it is so small it can be measured only in billionths of a watt. It is therefore, very essential that the antenna system shall "collect" as much of this energy as possible.

Before we go any further, it might be well to explain the words as they are used in this book. Quite frequently, people use the words "*aerial*" and "*antenna*" interchangeably. The word "*aerial*" refers only to the *flat top portion* of the entire system; whereas the "*antenna*" is the *entire* system comprising aerial, lead-in (transmission line), and ground.

The more energy the aerial delivers to the receiver, the less amplification is required; the less amplification required, the less likelihood of distortion, and the smoother is the operation of the set.

### Man-Made Static

Unfortunately, there are in the air other *electro magnetic waves* to which the aerial responds. These waves are created by natural atmospheric conditions (familiarly known as "static"), and by electrical machinery such as trolleys, dial telephones, motors, electric fans, automobiles, airplanes, heating appliances, flashing signs, oil burners, etc. (known as "man-made" static). Unless the proper precautions are taken in the installation of an antenna system, these noise "signals" will be so loud in the receiver as to completely over-

ride the radio signals or, at least make reception anything but pleasant. (See Figs. 1 and 2.)

At the present time, nothing can be done about atmospheric static; it simply has to be endured. However,

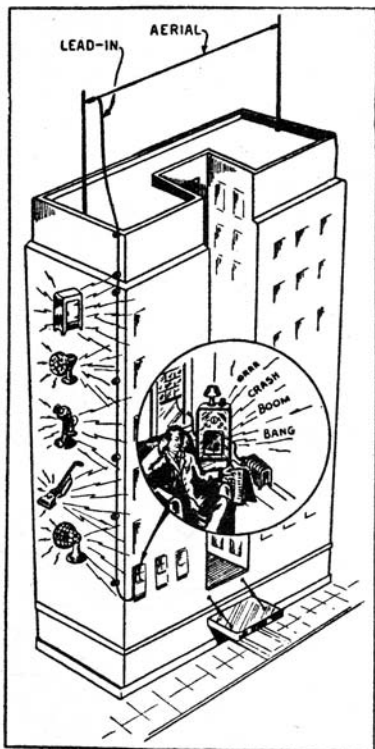

Fig. 1. Some of the sources of man-made static. Note the position of the lead-in wire in the field of noise.

such unfavorable atmospheric conditions are not always present, at least not to the extent where they become a nuisance. Man-made static, on the other hand, *can* be prevented from entering the receiver.

In the old days of the crystal set, prime importance was attached to the installation of the antenna. The crystal receiver, being a very insensitive instrument, required a fairly healthy signal. The antennas therefore, in those days were usually erected at a fairly high altitude, and consisted of five or six parallel wires, all uniting in a common lead-in to the set. (See Fig. 3.) The performance of these crystal sets was very seldom hampered by noise *due, mainly, to the elaborate carefully-installed antenna system.*

In recent years, both the power of broadcasting stations and the sensitivity of modern receiving sets have been increased tremendously; so much so that many people have resorted to the use of a short length of wire dangling outside the window, a heating radiator or an "aerial eliminator" gadget as the aerial — the result being *noisy reception.*

If these noise disturbance waves sweep across the *aerial* (the flat-top portion of the antenna system), then no power on earth can prevent them from entering the receiver. But such a condition can easily be remedied by removing the aerial from the field of disturbance. That is done by placing the aerial some distance from the equipment known to be causing the disturbance.

If the aerial is removed from the field of man-made disturbance, then

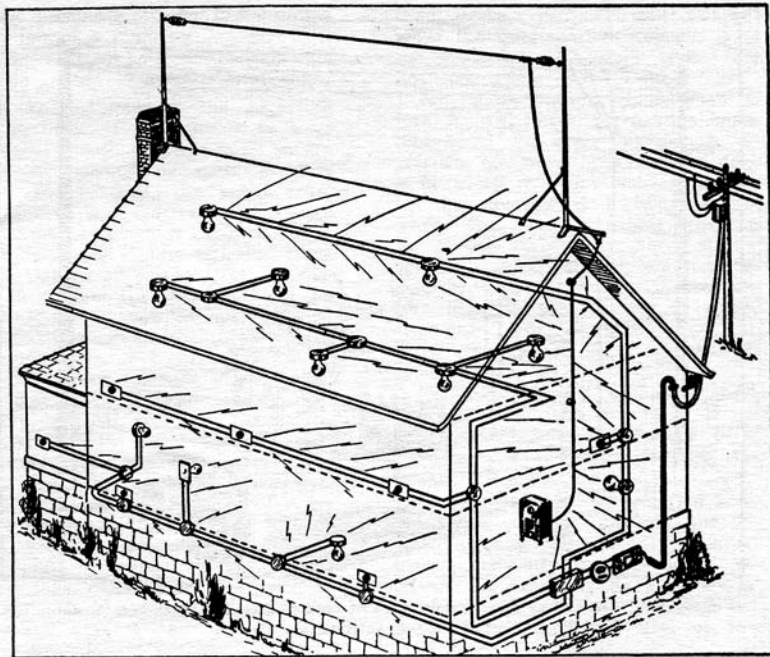

Fig. 2. Note the noise radiated from the house wiring. Indoor aerials or "ground" aerials pick up all this noise.

this noise can enter the modern shielded receiver in only one or both of two ways: either through the lead-in wire which unavoidably, must pass through the noise field, or through the electric line. A suitable *line filter*, inserted between the power plug of the set and the electric outlet, will remedy this latter condition. The prevention of noise from entering the lead-in, however, is a more complex

subject for discussion and correction.

Modern homes and apartment buildings which are equipped with electric service are fairly "alive" with electrical disturbance. (See Figs. 1 and 2.) These disturbances are in the nature of *radio-frequency waves* radiated by the electric wiring of the house, from the sparking of commutators or other make-and-break contacts on motors and other

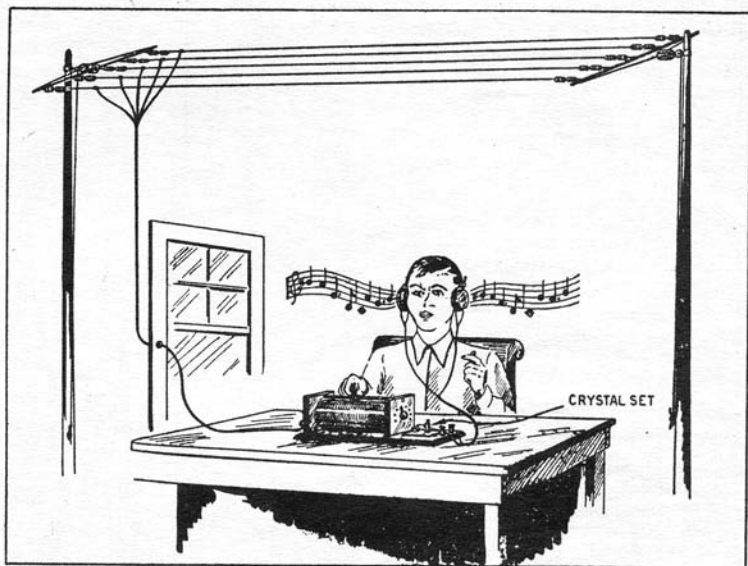

Fig. 3. Clear, noise-free reception in days of crystal sets due to elaborate, carefully constructed antenna system.

electrical appliances and machinery. These radio frequency noise waves are not radiated very far; hence, if the aerial is placed high enough above the roof, it will almost always be out of the field of such noise. The lead-in wire, on the other hand, is directly in the field and, therefore picks up most of it. It stands to reason that if a lead-in system can be devised which is immune to the reception of such radio-frequency noise, the problem of noise pickup by the antenna system would be substantially solved.

### Indoor Aerials Not Recommended

From the above discussion it should be clear that any type of *indoor aerial*, whether a metallic tape run under the floor rug, a wire dangling from a nearby window, or an "aerial eliminator" gadget, is not a very desirable aerial. It is merely a good noise collector.

Regardless of how sensitive a receiver may be, and of what claims to the contrary manufacturers or distributors may make to sell their products, a good

outside antenna is essential to the proper operation of a radio set.

### Tuned Aerials

As pointed out at the beginning of the book, it is desirable to have the aerial absorb as much radio energy from the surrounding space as possible. To do this, the aerial must be "tuned" to the exact frequency of the station which is being received; for it is a well known fact that maximum transfer of energy from one circuit to another (in this case from the transmitting antenna to the receiving antenna) is obtained when both circuits are "tuned to each other." That is when they are resonant at the same frequency.

In order that an aerial shall resonate at a given wavelength, it must be one-fourth, one-half, or else the exact length in meters of that wave. Thus, for instance, in order for an aerial to absorb the maximum energy from a 100-meter wave, the aerial itself must be either 100, 50 or 25 meters long. (One meter is equivalent to 39.37 inches.) The full and the half-wave antennas are generally of

the "ungrounded" (Hertzian) type; while the quarter-wave antenna is of the grounded (Marconi) type. (See Fig. 4.)

The ideal antenna system, therefore is one where we have a separate aerial for every wavelength. In practice, however, this cannot be done in broadcast reception — though it may be in commercial "point-to-point" work. The next best thing, then, is to choose such a length that the aerial will respond to a group of wavelengths; even though it does not absorb the maximum amount of energy from any one of them. Such an aerial is said to have "broad response."

For the standard broadcast band, the exact length of this aerial is not of great consequence, generally being from 60 to 125 feet including the lead-in wire.

For good short-wave reception however, it is necessary to have the antenna actually resonant to the particular wavelength that is being received. In order to do this, special antennas known as "doublets," are used. These doublets consist of two

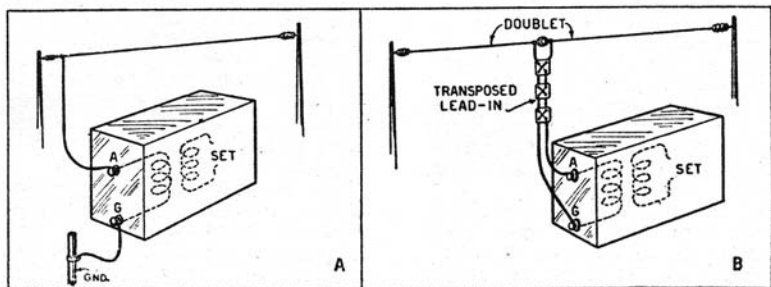

Fig. 4. Left, Marconi Inverted "L" Antenna. Right, Hertzian Doublet Antenna.

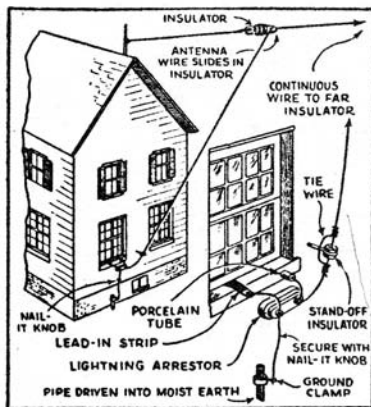

Fig. 5. Proper installation of an inverted "L" antenna.

flat-top portions each measuring  $\frac{1}{4}$  of the length of the wave to be

## BROADCAST RECEIVING ANTENNAS

The familiar Marconi inverted "L" antenna is still the most popular for general broadcast reception (200 to 550 meters) in rural districts, where the electrical noise level is negligible. Both the aerial and the lead-in may consist of a single wire of a *total* length of 125 feet. When it is correctly installed, excellent reception may be obtained.

The best means of supporting the antenna is by two rigid poles; one preferably on the house and the other mounted about 50 or 60 feet away, so that the antenna is clear of the ground by the greatest distance pos-

sible. A doublet is very efficient when receiving a radio wave *to which it is naturally resonant*. For all other wave-lengths, it is inefficient. By *tuning* the doublet, however, its efficiency can be extended over a range of wave-lengths.

For "all-wave" reception, the range of wave-lengths covered (10 to 2100 meters) is much too great to be covered even by a variably-tuned antenna system. For this service, therefore, there has been developed an antenna system known as a "double doublet" in which two separate dipole (doublet) aerials are used; one being of relatively large dimensions, for intercepting the larger wave-lengths, and the other of small dimensions for the lower or short wave-lengths. These antennas are all discussed, separately further on.

(See Fig. 5.) A metal roof underneath the aerial wire will tend to reduce its efficiency somewhat, since the effective height is reduced. Trees are not desirable supports for any type of aerial, because of their tendency to sway and cause "fading," as well as to absorb radio energy and thus reduce the signal strength.

It is important that the horizontal span—the aerial proper—be as far as possible from chimneys, walls, trees or any other wires; the lead-in, too, should be kept "in the clear" and well away from rain spouts, telephone or power wires, tree branches or any

other such objects. The lead-in should not approach the side of the house closer than six inches. These points are all illustrated in Fig. 5. Note that the aerial wire should be *one continuous length* with the lead-in. To keep the lead-in from sliding back and forth in the end insulator, a tie-wire may be used as shown in the illustration.

The lightning arrester is mounted on the outside of the house, in order that its ground post may be connected directly to a "driven" ground. This is made by driving a five or six-foot metal pipe or rod into moist earth, leaving the "above ground" section protruding only about six inches — enough to get a good ground clamp securely fastened to it. For the antenna, use at least No. 14 B & S stranded copper wire, or even No. 12, if possible. Keep the antenna and ground leads well apart at all points. Locate the radio receiver as close as

possible to the point at which the lead-in wire enters the house.

Important points to keep in mind are: Sufficient (A) height; (B) good insulation; (C) freedom from surrounding objects. Because of the somewhat directional characteristic of this type of antenna, it is wise to try various positions (such as east to west or north to south) for best all-around reception on the broadcast band.

## Low Impedance Transmission Line

In cities, where the man-made static noise level is quite high, the inverted "L" antenna may still be used, but with a modification as regards the lead-in wire. Since this is constantly in the field of noise disturbances, it is necessary to find some lead-in wire which will reject these foreign noise signals.

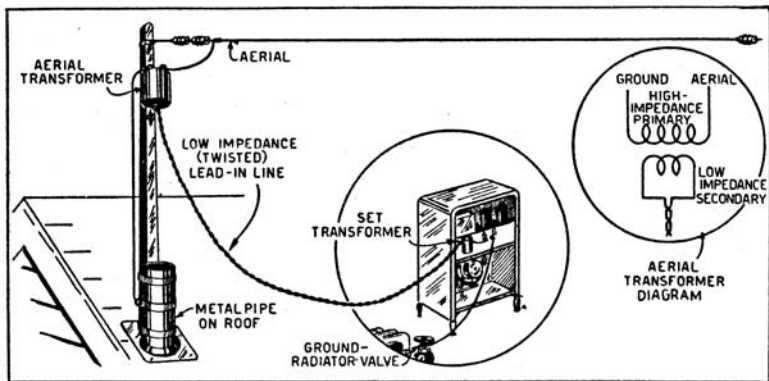

Fig. 6. A complete antenna system using aerial and set transformers and low-impedance transmission line.



It is an established fact that a *high-impedance* transmission line (lead-in) is very sensitive to waves caused by noise radiation. This is due to the relatively large electromagnetic field surrounding such a transmission line. On the other hand, a *low impedance* line, having a much smaller electromagnetic field, is considerably less sensitive to these noise disturbances. Therefore, if a low impedance transmission line is used to carry the radio current from the aerial to the set, less noise will enter the receiver. The impedance of an aerial is quite high and, therefore in order that the radio currents may be transferred to the low impedance transmission line, it is necessary to use a step-down transformer. Such a trans-

former is illustrated in Fig. 6. The primary winding "matches" (has the same impedance as) the impedance of the antenna; the secondary winding terminates in the low-impedance transmission line. At the receiver, a similar transformer is used to adjust the low impedance of the line to the original high impedance of the antenna and, since this transformer is mounted very close to the set, with short wires, there is no possibility of noise entering the set. As a further precaution, the two lead-in wires are twisted around each other; so that the electro-magnetic fields of any noise currents which might enter the transmission line, will automatically be cancelled out at the transposed junctions.

## DOUBLET SHORT-WAVE RECEIVING ANTENNAS

**A** TUNED doublet antenna is extremely efficient for the reception of fundamental and harmonic frequencies which are related to the natural period of resonance of the antenna. A doublet is also highly directional, receiving best from directions at right angles (in the case of half-wave doublets) to the line in which the two flat-top portions of the aerial are stretched. The respective characteristic of a half-wave doublet, whose two wires or "dipoles" run in a straight line North and South, let us say, will be directional East and West. Now, by tilting the doublet so that the South end, for instance, is low and the North end high, an added directional preference

to southern signals will be observed. When the two flat-top sections are not running in exactly the same directions, or their lengths are unequal, the doublet effect is reduced, the directional preference is changed, and the antenna system begin to function as an aerial and counterpoise, with a tendency towards broadness in the reception of signals.

A doublet antenna, therefore, provides maximum signal response on signals and wavelengths which have a certain relationship to the length of the flat-top portion of the antenna system; and this characteristic, ordinarily, is unaffected by the length of the transposed R.F. transmission line provided it is not a multiple of

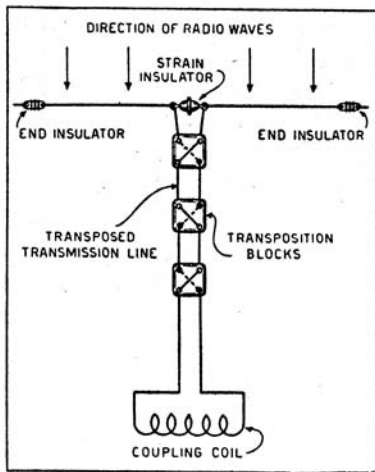

Fig. 8. Diagram showing fundamental design of a doublet antenna.

the length of the flat-top portions. For best results on a given wave length, the lengths of the dipole sections (in Fig. 8) should each be  $\frac{1}{4}$  of the desired wavelength. The total length for the two dipoles of the doublet is conveniently obtained by dividing 492,000 by the desired frequency in kilocycles. On very short wavelengths one twentieth may be deducted from the figure obtained. The result is the length of the *entire* flat-top, in feet; this length is now halved by breaking the length with a strain insulator placed at the exact center. Of the four dipole ends thus formed, two terminate at this strain insulator and connect to an R.F. transmission line, or twin-conductor lead-in, whose wires are at intervals

transposed. The two outer ends terminate in end insulators. (See Fig. 8.)

### Transposed Lead-In

The two wires that compose this transposed lead-in are interchanged every few inches in their respective positions, in order to eliminate the pickup of local interference. This reduced pickup of noise is due to the fact that (See Fig. 9) any energy induced in Section "A" is neutralized at the transposition point "B" by the energy simultaneously induced in the other section "C". Of course, if the radio waves created by man-made static sweep over the flat-top sections of the doublet, then the transposed lead-in will be of no avail to prevent these interference currents from entering the receiver. It is, therefore, very essential, as has already been repeatedly stressed in this book,

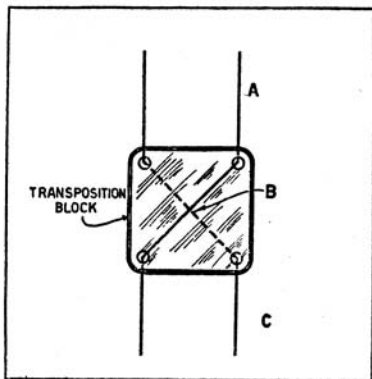

Fig. 9.

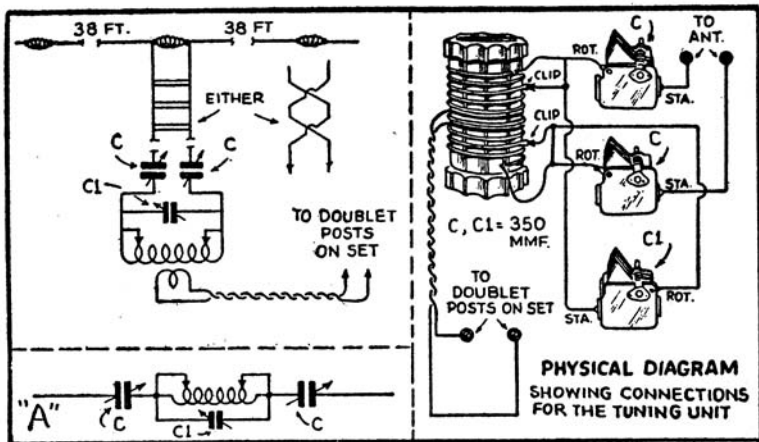

Fig. 10. A tuned doublet antenna. The antenna is "tuned" by varying condensers C, C1, and by shorting out turns on the coupling coil.

that these flat-top sections of the antenna be placed in a noise-free area, as high as possible above the roof.

The main requirements for a good antenna are "pickup" and the rejection of unwanted noise. We can obtain plenty of pickup by putting up an aerial several hundred feet long; but an aerial of this type will pick up not only radio signals, but noise signals as well. What we want, therefore, is *pickup at the precise frequency on which we are receiving* so that the desired signal will be far stronger than the noise level. This is to obtain as much signal voltage for our detector as possible. For short-wave reception we do *not* want an antenna of uniform pickup over a very wide range of frequencies be-

cause, with such an antenna, we are also picking up noise over *that* entire range and feeding it to our receiver along with a very feeble amount of voltage which constitutes the signal we are trying to receive. With such a system it can be readily understood that there is every possibility of the noise level exceeding the signal level. On the other hand, we may live in a neighborhood where the nature of the noise is such that it peaks at a certain frequency, say 39 meters, whereas we are listening to the 49- or 31-meter broadcast station. This means that our *general coverage* antenna is picking up the noise as well at the station, while that particular station's frequency may be more or less free of noise.

Now, merely putting up a doublet antenna will not remedy this condition. The only condition under which a doublet, with transposed or twisted feeders, does eliminate noise is *where the two flat-top sections of the antenna are out of the field of the noise.* Even with these precautions, a doublet may be of little use if the noise that troubles us is caused by an electric sign or some other instrument located several hundred feet, or even a quarter of a mile, away. What we need, therefore, is an antenna which is very sensitive to the particular frequency on which we are receiving — one that discriminates against noise coming from adjacent wavelengths, in very much the same manner as our receiver discriminates between (is able to separate) various stations.

With our present knowledge of antennas, we cannot as yet design such a perfect system; *but we can design one that will be sensitive at one particular frequency, thereby obtaining enough signal voltage from the station to override the noise level.* This antenna design is nothing new for engineers in the short-wave transoceanic telephone service have been using it for years. They have antennas that are resonant to the frequency of the station they wish to receive.

A doublet antenna, whose dipoles are each a quarter-wavelength long, will resonate at one particular frequency. At this frequency (meaning the lowest frequency at which it will resonate), it will be a half-wave doublet antenna. Now, if we operate this antenna with a receiver tuned to some frequency other than this (or a

harmonic of it) it will not be a half-wave doublet. In fact, it is no longer a doublet, it is just a piece of wire cut at the center and not very effective except, as we said before, at the particular wavelength which is just twice the length of the antenna in meters. We can expect this antenna to work well only on one wavelength, an odd harmonic of this wavelength (if twisted pair is used as a transmis-

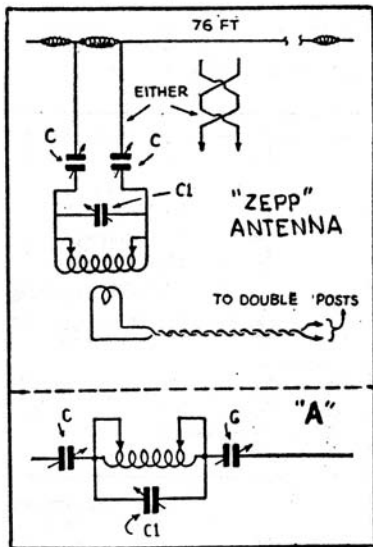

Fig. 11. Tuned "Zeppelin" Antenna. The tuning system is the same as that shown in figure 10.

sion line) or an even harmonic if spaced feeders are used.

This undoubtedly will bring to some minds instances where the doublet gave less volume on a station than a plain antenna and ground. True, the noise level is down, but so is the station. This is because the ground-and-antenna combination is broader in response than the doublet; with the doublet giving less volume because it is not being operated in its own "natural period of resonance." A doublet, being so much sharper than other types of antennas, is the worst type to use for general short-wave reception, unless we make some arrangement for tuning it.

## Tuning Doublet Antennas

In Figs. 10, 11 and 12, we illustrate very practical methods of tuning antennas in order to bring up the strength of the stations so that they will at least be "in the running" with the noise! In Fig. 10 we have a real doublet, the resonant period of which can be adjusted by the three condensers and the coil. To make this clear, we consider the antenna as one single wire, as in Fig. 10a. Its "electrical length" can be shortened by reducing the capacity of condensers "C." To make it work as an antenna longer than it really is, we "short out" condensers "C," and use condenser "C1" and a coil which is

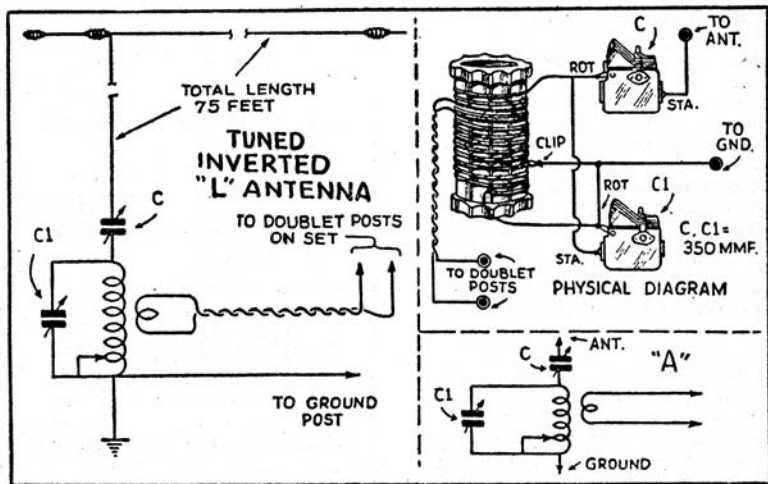

Fig. 12. Tuned inverted "L" Antenna system for use in low noise level districts. Details of tuner shown physically at right hand side of diagram.

equipped with a clip to "short out" the unwanted turns. Now if we "fold" the antenna as shown in Fig. 10, the fields of the lead-in section will cancel and reduce the danger of picking up noise. In Fig. 11, we have the same system but there is only one flat section and it is not split. The flat section, however, is the same length as the whole of the flat-top of the doublet. This antenna is commonly called the "Zepp", because it was originally designed for use on Zeppelins. The feeders should be spaced with  $1\frac{1}{2}$  to 2-inch ceramic (porcelain) insulators; or they can be transposed with transposition blocks. The two condensers marked "C" are to be varied simultaneously, but the ratio between the two should be varied slightly, by either advancing or retarding one or the other, in order to obtain the least background noise. These condensers, besides tuning the system, can be used as "phasing" adjustments to bring the currents in each feeder just opposite, so that fields will cancel and, if they are run in the field of some electrical disturbance, they will tend to reject the noise. The above holds true for both Figs. 10 and 11.

## How to Build a "Tuner" for Short-Wave Antennas

Figure 12 shows just a single wire which is equipped with a coil and two condensers. Condenser "C" reduces the effective length of the wire, while "C1," together with the coil, lengthens it. This antenna is just as good as the other two when used in a neighborhood with extremely low noise level.

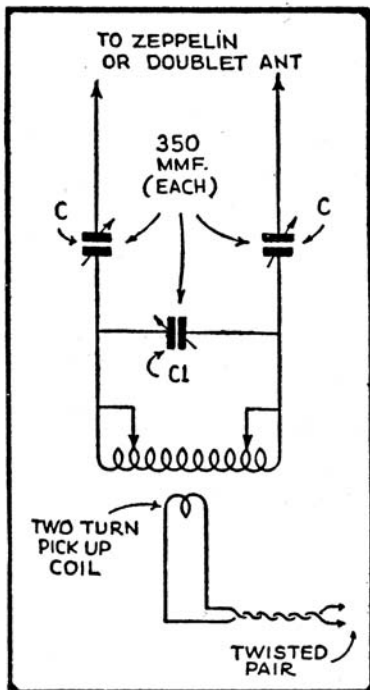

Fig. 13. Enlarged diagram of tuning units shown in illustrations 10 and 11.

The coil used in this type of antenna is wound on a  $2\frac{1}{2}$  in. diameter ribbed coil form and has 26 turns of No. 12 or 14 bare, tinned copper wire. It will be necessary to make a small clip to fit the wire for varying the number of turns. The receiver pick-up coil has two turns of cotton-covered wire (No. 18 hookup wire

will do) interwound with the bare wire. For the antennas in Figs. 10

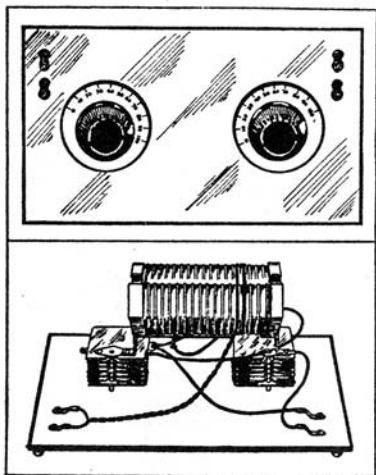

Fig. 14. General appearance of the inverted "L" antenna tuner.

and 11, it should be placed exactly in the center of the large coil; for Fig. 12, it should be placed four or five turns from the antenna end of the coil. Only one "shorting" clip is needed for the antenna in Fig. 12, but two for those of Fig. 10 and 11. Condensers "C" and "C1" have a capacity each of .00035 mf.

For short-wave reception, do not use twisted pair or similarly close-spaced wire for the feeders; because the high "distributed capacity" between these wires makes it difficult to tune the antenna.

Tuning this type of antenna coupler is quite simple after the initial ad-

justments for each wave band have been determined. The number of turns used in the coil for the antennas, shown in Figs. 10 and 11, will depend upon the length of the feeders or lead-ins. The feeders of Fig. 10 should be between 55 and 65 feet long for best results. For the "Zepp" antenna, the feeders should be no less than 35 feet long and can be as long as 75 feet. This system is not as flexible as that shown in Fig. 10.

In operation, set the "shorting" clips so that about one-third of the coil is not in use; set "C" to maximum capacity, and vary "C1" and the turns in the coil until the signal is loudest. Then try for a combination of both "C" and "C1" which will give a still stronger signal with *less noise*. The leads of the two-turn coil should be connected to the "doublet posts" on your receiver. If you have no provision for this connection, then connect them to the "antenna" and "ground" posts. (The *ground* post of the receiver should always be *grounded*.) If one doubts the practicability of tuned receiving antennas, one has only to ask the question—*why transmitting antennas are always tuned*—and the answer is obvious.

Figure 13 shows the schematic drawing of the coupler designed for use with either a doublet or a "Zepp" antenna. Note that there are two clips, and these should be placed at equal distances from the center; the exact locations depending upon the length of the feeders, or the frequency on which it is being operated. Three condensers are used with this instrument, while only two are used in the tuning unit for the Marconi

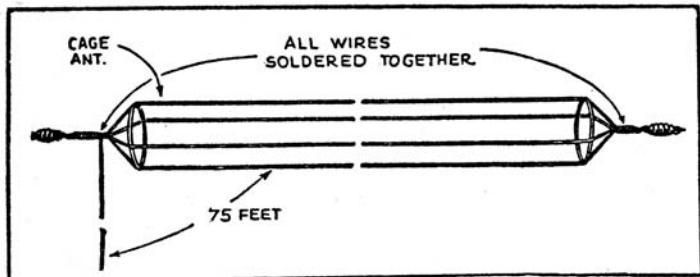

Fig. 15.

(Inverted "L") antenna. The tuner for the Marconi antenna is shown in Fig. 14 and a general idea of the construction and assembly can be obtained by referring to it.

### Cage Antennas

Many comments and suggestions have been offered regarding the use of "cage" antennas. However, we have yet to see actual proof of one of these antennas giving better results than a single wire. During tests, absolutely no difference could be noted between the single-wire antenna and the multi-wire affairs, such as the cage. However, we have no fault to find with this type of antenna, and should the reader desire to construct an antenna, of either the doublet or Zeppelin type, using the cage principle, he may do so—but no increase in signal strength should be looked for. The construction of a cage antenna is shown in Fig. 15.

### Antenna Construction

A few words might be said at this time regarding the type of insulators,

wire, and general construction of antennas. Fig. 16 illustrates a typical doublet antenna system.

One point which should be stressed is the use of good insulators, and plenty of them! If *small* insulators are used, about two or three inches long, it is advisable to use *two or three of them connected in series* with short pieces of wire. Isolantite (or other good ceramic insulators) or Pyrex glass insulators are the most efficient, and are recommended in every case. Then too, the tie-wire (that is, the wire supporting the antenna), if of any appreciable length, should be broken up every three or four feet with an insulator. If possible, of course, it is best to use a rope rather than a wire. All connections in the antenna should be well-soldered.

Splices, whether soldered or not, should be avoided wherever possible. The down-lead or feeders, which ever you prefer to term them, should be kept away from all metal leader pipes, telephone wires, electric wires, or any other metal. Keep the aerial



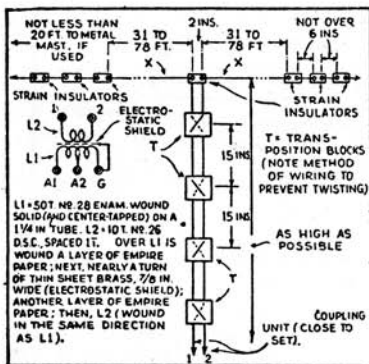

Fig. 16. Typical Doublet Antenna System.

well out in the clear, and away from trees whose branches might come in contact with it. If your antenna is

supported by a mast, by all means try not to use metal. If possible, the mast should be constructed of wood, and any guy wires supporting it should be broken every few feet with an insulator. If a metal mast is used to support the antenna, don't run the end of the aerial too close to it! A good separation is fifteen or twenty feet.

## The Ground

When a ground is used, and connected to a water pipe, make sure that you attach it to the pipe where it enters the building if you are on the ground floor. Long ground wires are not very desirable; and considerable noise may be picked up by this wire even though it is grounded at one end. In apartment houses it is permissible to ground the receiver to a steam or hot-water radiator.

## DOUBLE-DOUBLET "ALL-WAVE" RECEIVING ANTENNA

FIG. 17 illustrates a complete installation of a "double doublet" antenna as developed by one of our foremost radio manufacturers.

The purpose of this arrangement is to approach an ideal antenna system for all short-wave bands, as well as for the standard broadcast band. Theoretically, as shown in our discussion of doublet antennas, it would be best to have a separate doublet designed and installed for each band; that is one each for the 16, 19, 25, 31 and 49-meter bands. This would mean five doublets, and each one would have to be sufficiently separated from

its neighbors to prevent disturbance of reception. Obviously, this would be quite an installation problem and, financially prohibitive. The system illustrated in Fig. 17 was developed as the best approach to the ideal. The 29-foot sections tend to tune or match the system towards the lower frequency end of the short-wave broadcast band (that is, towards 49 meters), while the 16½-foot sections tend to tune the system towards the higher-frequency end of the band (that is, toward 16 meter).

The proper lengths for each doublet made from two continuous aerial

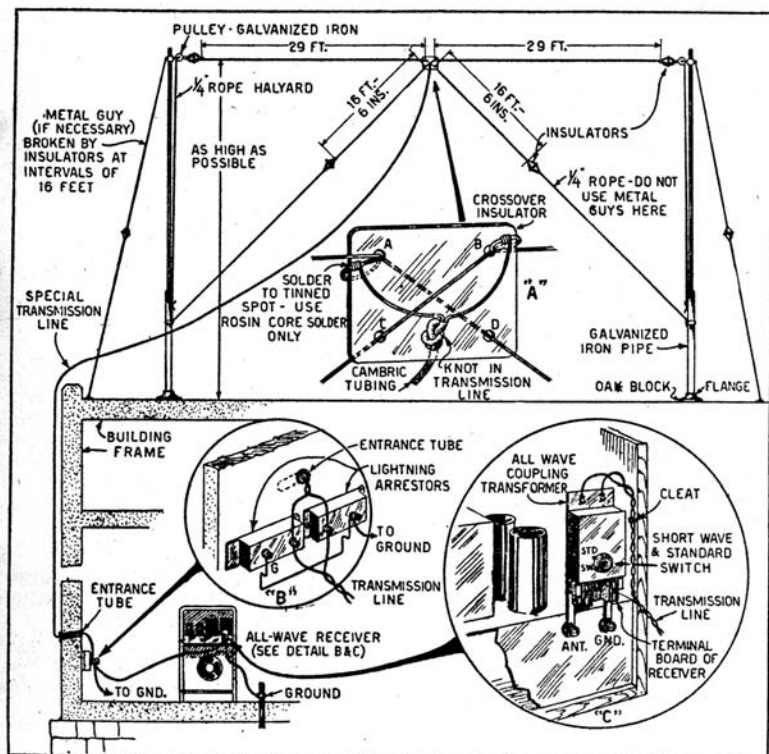

Fig. 17. Complete installation of a double doublet antenna system for "all wave" radio reception.

wires, each  $46\frac{1}{2}$  feet long (6 in. allowed for each aerial strain insulator) are indicated in Fig. 17. The inset in the illustration shows the proper method of connecting the transmission line to the two doublets. Note that

the long and short aerial wires, which are connected together, are located on opposite sides of the transmission line's connecting insulator. For good results, a minimum of 30 feet above ground (or above the roof, if located

on a steel building), is recommended. The signal strength received increases with the height above ground.

Theoretically, the horizontal dipoles should be stretched out fully—each section in line with the other, as shown in the illustration—for most efficient reception. If this angle is reduced, under installation difficulties, to 90 degrees, the signal strength will decrease about 30%, as compared with that received from the horizontal doublet in its full 180-degree span.

The total 110 foot length special transposition cable (which is not merely a twisted pair) must always be used, regardless of whether the doublet antenna system reaches the receiver with as little as 60 feet of line. The balance of 50 feet, in such an instance, should be *coiled up* at the receiver end. For distances greater than 110 feet, an additional 110-foot *full length* lines must be added; and so on, up to 500 feet. After that the line is no longer critical.

A special coupling unit is furnished by the manufacturer of this "double doublet" kit which serves four functions: (1) it couples the low impedance transmission line to the receiver; (2) by its design and use of electrostatic shielding, it balances out the capacity of the transmission line

to ground; (3) it balances out local interference picked up by the transposition line; and (4) it permits a ground connection to be used on the radio receiver, thus reducing any tendency towards hum or circuit instability. This coupling unit cannot be designed to match the antenna system to the receiver efficiently for *all* bands. It is therefore so designed that its greatest efficiency is obtained at the higher frequencies (lower wavelengths) of 3.5 to 2 megacycles (86 to 15 meters). This means that an unavoidable loss would be introduced on the frequencies assigned to standard broadcasting, police bands, etc., of from 500 to 3500 kilocycles. To get around this, a special switch is provided on the coupling unit, for improving the reception of the stations operating on the lower frequencies between 500 and 3500 kilocycles. Strong local stations can of course, in most cases, still be received with the switch in the short-wave receiving position.

It is important to note that the length of the ground connection of this coupler to the receiver is critical; therefore, to insure maximum noise reduction, it is necessary to keep this connection at the shortest possible distance (not over one inch) from the ground post on the chassis. \*

## HELPFUL SUGGESTIONS FOR DOUBLET ANTENNA INSTALLATIONS

A QUICK reference table is given for building antennas which resonate in *amateur bands*, these being in harmonic relation with one another. If an antenna is wanted to receive short-wave broadcast stations, *five feet* must be added to each of the figures given for antenna lengths,  $A^1$  and  $A^2$ . Likewise, 10 feet must be added to each of the feeder lengths given. This type of short-wave antenna, with tuned feeder system, is more noise-free than any other system yet devised. Because the system resonates at the frequency used by the transmitting station, it is obvious that maximum pickup will be attained.

### \*Correct Dimensions for Short-Wave Receiving Antennas

For all-around best results the antenna wires,  $A^1$  and  $A^2$ , designated in Fig. 18, 19 and 20 (but also applying to all other antennas shown here) should be of the following lengths:

20 meter rec.  $A^1$  &  $A^2$ , ea.  $16\frac{1}{2}$  ft. long  
 40 meter rec.  $A^1$  &  $A^2$ , ea.  $33\frac{1}{2}$  ft. long  
 80 meter rec.  $A^1$  &  $A^2$ , ea.  $66\frac{1}{2}$  ft. long  
 160 meter rec.  $A^1$  &  $A^2$ , ea. 133 ft. long

THE TRANSPOSED FEEDERS, for use with above antennas, are to be the following length:

For 20 meter reception.....  $33\frac{1}{4}$  ft. long  
 For 40 meter reception.....  $66\frac{1}{2}$  ft. long  
 For 80 meter reception..... 133 ft. long  
 For 160 meter reception..... 266 ft. long

\*Courtesy RADIO

However, even the smallest of these antennas, with corresponding short feeder lines, can be used for short-wave reception on *any* of the bands. The table is for the benefit of those who are situated in places where larger antennas can be erected. Obviously, the larger of the above antennas will be productive of much better results, but even the 20 meter antenna will improve reception on *any* short wave receiver. Its fundamental wave-length lies within the 20 meter band, but its harmonics will take in many corresponding bands.

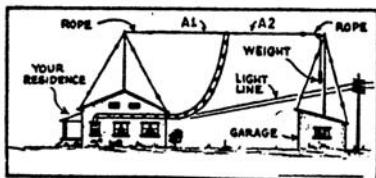

Fig. 18. Antenna placement for location where "lead-in" is close to power line.

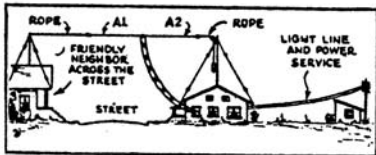

Fig. 19. Improved antenna, remote from power line. Note balance weight to keep aerial taut.

Remember that unless the two flat-top portions of the antenna are out of all noise fields, no amount of

feeder transposition will prevent noise from entering the receiver.

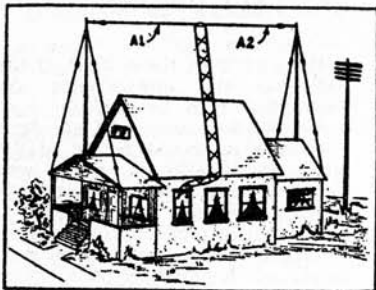

Fig. 20.

A placement (Fig. 20) that is only fairly good, but which will give satisfactory results if space is at a premium. The proximity of the antenna to the power line again makes it difficult to entirely eliminate all pick-up from the lines, especially in such places where a multitude of wires is attached by the power line pole. A condition such as illustrated in this Figure is found only in congested localities. For those who are confronted with this problem it is suggested that the antenna be run to an adjacent house, if possible.

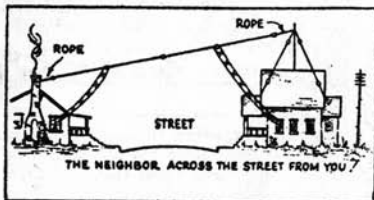

Fig. 21.

In Fig. 21 you give a neighbor a

helping hand by permitting him to use a perfect short-wave antenna of his own, while you, too, enjoy the full benefits from this method of placement. Note the insulator in the center of the antenna. This separates the two antennas, each having its own feeder system. This installation keeps your antenna away from the annoying power lines and both you and your neighbor will have the ultimate in short wave antennas.

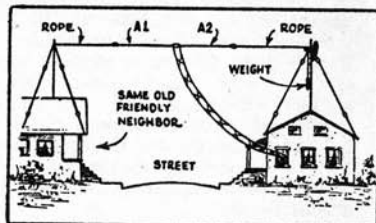

Fig. 22.

If your neighbor permits you to use his house for the far-end suspension of your antenna, and if he is not interested in the "community antenna" idea, erect the system in the way shown in Fig. 22. The feeder lines are attached to the center, with ropes of sufficient length at both ends to permit correct suspension of the antennas proper. This method keeps your antenna free and clear from the power lines.

The feeders of the antennas shown here should be tuned with a coupling coil, 1½ in. diameter, wound with 16 turns of No. 22 Double Cotton Covered wire. At the 8th turn, the wire is cut and a series tuning condenser inserted. (See Fig. 27.)



Fig. 23. Shows short-wave antenna with transposed lead-in erected over vacant lot, if your neighbor will permit you to anchor the antenna to the roof of his house.

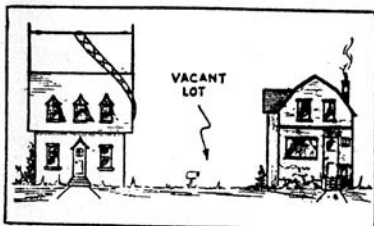

Fig. 24. Aerial construction where it has to be confined to the roof of your house. Erect aerial as high as possible and keep the feeders as far as possible from the side of the house.

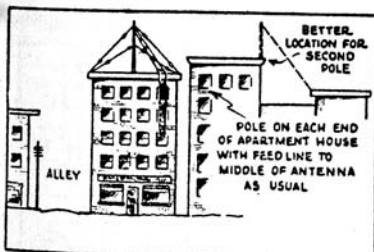

Fig. 25. Aerial construction with transposed lead-in for "apartment" houses. It is better to locate one of the supporting masts on the roof of a nearby house.

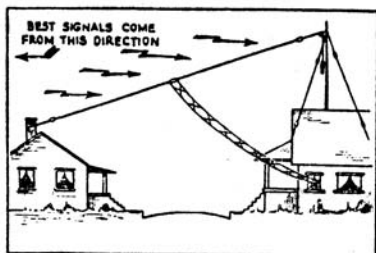

Fig. 26. Showing the use of sloping antenna to receive signals from a certain direction. Try various degrees of sloping for best results.

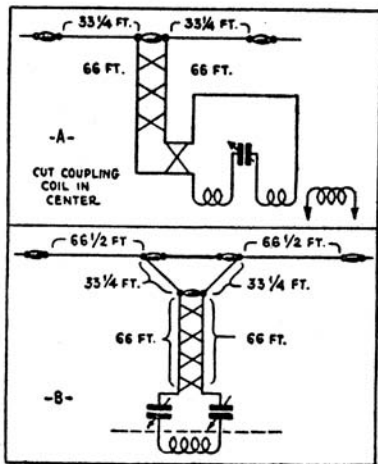

Fig. 27.

Diagram A (Fig. 27, above) shows a good coupling system, the coupling coil 1 1/2 inches in diameter being wound with 16 turns of No. 22 double cotton covered magnet wire. At the

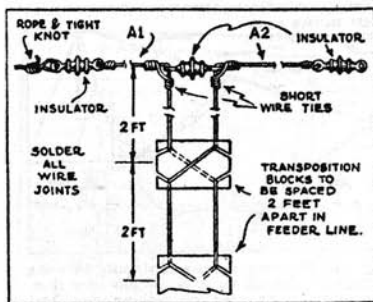

Fig. 28.

eighth turn the wire is cut apart and the two ends connected to the terminals of a 43 plate midget variable condenser which tunes the feeders. Diagram B shows how to tune each feeder separately; here the coupling coil is not split and two 43 plate midget variable condensers are used.

Fig. 28, left, illustrates the proper method of installing a doublet antenna with transposed feeders. Note the tie-wires on both sides of the center insulator.

## PART II

### TRANSMITTING ANTENNAS

for

### AMATEUR STATIONS

**O**NE of the most important parts of any transmitting station, is the *antenna*. Therefore, we will endeavor to point out in simple English the nature of each type of antenna and its various uses.

#### The "Half-Wave" Antenna

It is an established fact that a wire will resonate at wavelength twice as great as the actual length of the antenna in meters. This is called in radio circles a *half-wave* antenna. On the other hand, certain antennas, which

are apparently one-quarter wavelength

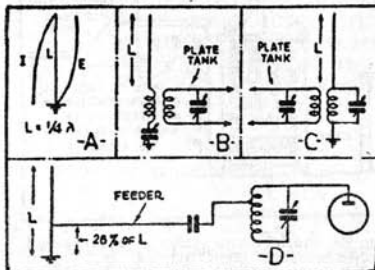

Fig. 29.

long, many may be used when operating against *ground* (Earth). This is shown in Figure 29A. The current and voltage distribution along an antenna of this type, which is commonly called the *Marconi antenna*, is shown by the curves I. and E. We notice that the point of maximum voltage is the *ungrounded* end, while the point of maximum current is at the *grounded* end. In Figure 29B and C, we show how this type of antenna may be tuned and coupled to a transmitter or receiver. In Figure 29D, we show a method of operating a Marconi antenna with an *untuned* transmission line. This transmission line is connected on to the antenna a short distance from the grounded end. Usually, this distance should be equal to 28% of the length of the antenna which, as stated before, is one-quarter of the wavelength. In Fig. 30A, we have the well-known *one-half wave* antenna. The length of this antenna in feet for any given frequency is expressed by the following formula:

$$L = \frac{492,000}{F} \times K = \text{feet}$$

Where L is the length of the antenna in feet, and the F is the frequency in KC., and K is the correction factor. Below 3,000 kc.  $K = .96$ . From 3,000 to 28,000 kc.,  $K = .95$ , and above 28,000  $K = .94$ .

### Points of Maximum Voltage and Current

In Figure 30A, we find that the point of *maximum current* is in the *center* of the antenna, and the point of *maximum voltage* is at the *ends* of

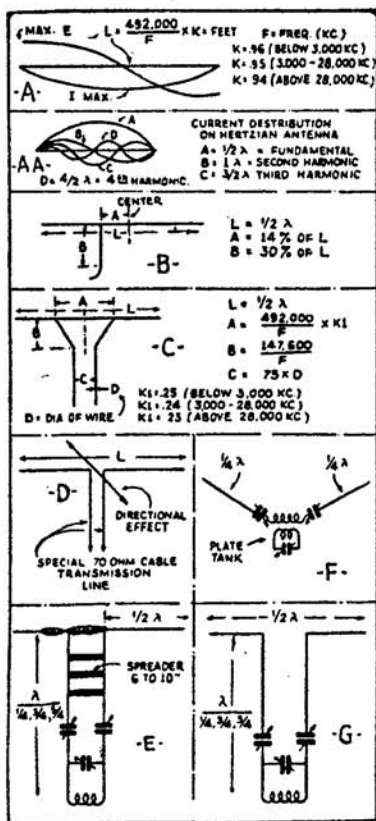

Fig. 30.

the antenna. This *half-wave* antenna is undoubtedly the most popular of all types.

In Figure AA, we find the entire



current distribution group for an antenna a half-wavelength long, one wavelength long,  $1\frac{1}{2}$  wavelengths long, and two wavelengths long. This corresponds to a single antenna operated on any one of these amateur

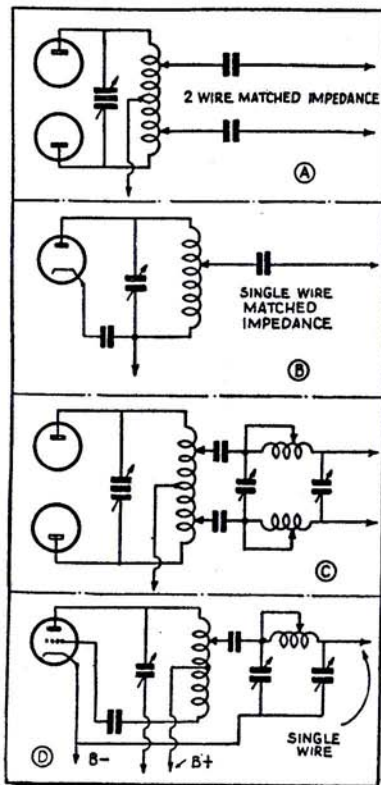

Fig. 31.

bands. If it were cut to operate as a half-wave antenna on 80 meters, for instance, it would be a full wave antenna on 40 meters, and the current distribution would be shown by curve B. It would then be said that the antenna was operating on the second harmonic, as a full-wave antenna. If the same antenna were operated on the 20-metre band, the current distribution, as shown by curve D indicates that it is operated on its fourth harmonic, and the antenna would be two wavelengths long. Now, curve C shows the current distribution when the antenna is operated on its third harmonic, or when there are three half waves standing on the antenna. For instance, if we wish to construct an antenna operated on its third harmonic on the 40-meter band, the antenna would have a length of three half waves of 60 meters. Third harmonic antennas are not very popular because the average Ham desires an antenna as short as possible. Antennas are usually fed or excited at the point of high current, or the point of maximum voltage when tuned feed lines are used. For instance, in the Zeppelin type antenna where the feeders are connected to the end of the antenna for a point of high voltage, the antenna is said to be voltage-fed. In the doublet type, where the feeders are connected to the center of the antenna, i.e., a half-wave antenna, it is said to be current-fed. Antennas fed at the center are only current fed when they are a half wavelength or an odd number of half wavelengths long. This is clearly shown by the curves A and C in Figure AA. If an antenna had a current distribution as shown in Fig. B or D and was fed in the center,

it would be said to be voltage-fed. Another method of exciting an antenna, which will be described later, is by an untuned transmission line matched in impedance to the antenna at any point which may provide the necessary impedance match. In Fig. 30—B, C and D, we have this sort of an antenna.

In Figure 30B, we have what is known as the *single wire matched-impedance feed system* which consists of a single wire attached to the flat-top *slightly off center*. The distance (A) between the center of the antenna and the point where the feeder is attached, is equal to 14% of the total length of the antenna, flat-top. With this type of antenna, the feeder should be run at right-angles to the flat-top for a distance of at least 30% of the length of the antenna. In Figure 30C, we have the two-wire feed matched impedance antenna, using a 600 ohm transmission line. The dimensions are:

$$A = \frac{492,000}{F} \times K^1$$

$$A = \frac{147,600}{F}$$

and  $C = 75XD$ .  $K^1 = .25$  for frequencies below 3,000 kc., .24 from 3,000 to 28,000 kc., and .23 for all frequencies above 28,000 kc., and D is the diameter of the wire. In other words, the spacing between the two feeders should be equal to 75 times the diameter of the wire. This antenna

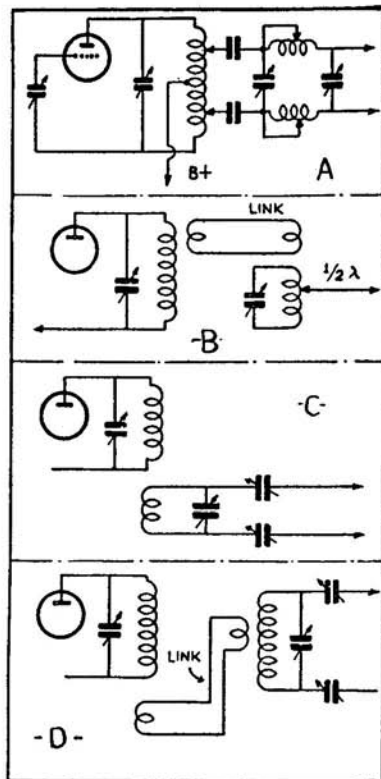

Fig. 32.

should also have its feeder system running at right angle to the flat-top for a considerable distance. Tests have proven that when a half-wave antenna is split in the center (Fig. 30D) it represents an impedance of

70 ohms at this point. Recently, various cables have been introduced on the market having a characteristic impedance of 70 ohms. This type of cable can be connected directly to the center of a half-wave antenna.

In Figure 30E, we have the very popular *half-wave Zepp* antenna which is voltage fed by a pair of "folded-up" feeders. The length of the feeder systems, in this case, is quite important because they form part of the antenna, although they do not radiate because the fields about the two wires cancel, being 180 degrees out of phase. In Figure 30F, we have the half-wave antenna *current fed* (meaning the antenna is fed at a point of maximum current) in the center with a coil and two tuning condensers used for tuning the antenna to exact resonance with the transmitter frequency. The disadvantage of this type antenna, of course, is that the *radiating* portion of the antenna is usually brought directly into the transmitter room.

In Figure 30G, we have the half-wave antenna with a tuned feeder system connected to its center. This is also a *current-fed* antenna system when the total flat top length is equal to one-half wavelength. The feeders of this system will have approximately the same dimensions as those for the Zeppelin antenna, i.e., they can be  $1/4$ ,  $3/4$ ,  $5/4$ , etc., any odd number of quarter waves in length. All of these half-wave Hertzian antennas are quite directional at right angles with the plane of the antenna; in other words, should an antenna point north and south, it would be directional east and west.

## Aerial Constructional Details

The most important elements of any antenna system are its height and insulation. The Hertzian antenna, regardless of the type or how it is energized, should be as high as possible. The average height above ground for best results should be at least  $1/4$  wavelength. Insulation, wherever used, should be glass or preferably glazed porcelain or isolantite, and the insulation of the ends of the antenna should be from 8 to 12 inches. In draping the feeders about the "shack", all sharp bends should be avoided. Wherever a bend is necessary, it should be well rounded out rather than making a sharp angle. Another important part of an antenna system is the method of coupling to the transmitter. In Figure 31A, we have the usual connections for the two wire-matched impedance antenna. In Figure 31B, we have the *single-wire* antenna connected to a single-ended power amplifier. Both of these antennas should be connected through condensers in order to keep D.C. plate voltages out of the antenna system. In Figure 31C, we have the well-known *impedance-matching* network, wherein two variable condensers and two coils are used for tuning and matching a two-wire feed system to the transmitter. Such an antenna tuning device, and the correct impedance match which it provides between the antenna feeders and the amplifier, have proven to be very efficient, and many times increase the effective radiated power of the transmitter a goodly percentage.

In Figure 31D, we have the same type of antenna-matching device except that only a single coil is used. This is for coupling a single feed system or a single wire of any convenient length to a single-ended amplifier. The two-wire feeder system can be coupled to the single-ended amplifier merely by making both ends of the tank coil *hot*. This is done by feeding the B plus or the low R.F. potential portion to the center of the coil. This is clearly illustrated in Figure 32A. Many amateurs have reported excellent results with a well-known German antenna wherein a separate tuned circuit is used to couple the antenna to the transmitter. In Figure 32B, we show the Fuchs antenna link-coupled to the plate coil of the amplifier. With this type of antenna a very loose coupling is needed, otherwise it would be almost impossible to get the antenna into resonance

with the transmitter frequency. In Figure 32C, we have the usual inductive coupling where the antenna coil is coupled to the low potential end of the plate coil and the transmitter. Coupling is varied by changing the distance between the two coils. This type of feeder system may also be link-coupled to the amplifier as shown in Figure 32D.

All types of tuned coupling, except impedance-matching networks, should be tuned to exact resonance and the coupling made loose rather than close coupling with a detuned antenna. This takes in the usual systems used with the Zepp and doublet type antennas, which are tuned with a coil and condenser combination.

The plate circuit of the amplifier should always be reset to resonance after each antenna adjustment, except where the matching network is used.

## TRANSMITTING ANTENNA CONSTRUCTION

**M**ANY Ham operators are in difficulty when it comes to erecting efficient antenna systems for their transmitters. Some are not fortunate enough to have "back yard space." Others are hindered by power lines and other nuisances which prevent them from "getting out."

In the following paragraphs we will try to clear up some of the outstanding faults of amateur radio antenna equipment.

### Proper Insulation Important

A properly insulated antenna will increase the efficiency of any trans-

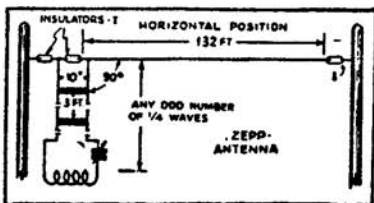

Fig. 33.

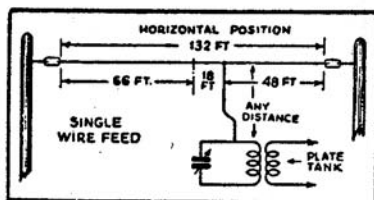

Fig. 34.

mitter. Antenna systems should be erected in the open if possible. Wire for both antenna and feeders should be of single strand copper, No. 12 gauge. No. 14 wire may be used if No. 12 cannot be secured. Feeder wires should be kept at least a foot and one-half from buildings and wires. Insulators should be four inches long, and two of these should be fastened together for insulating one end of the antenna. *Never connect transmitting antennas to metal poles.* The antenna current will be absorbed by the pole, and there will be change in frequency for which it is hard to compensate.

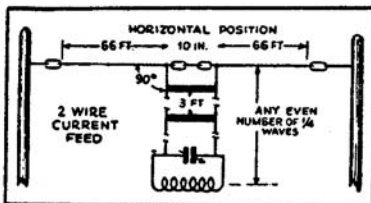

Fig. 35.

The 80 meter band is usually the most popular for the beginning "Ham", and therefore all antenna data is given for this band. Of course,

if higher frequencies are to be used, dividing the given antenna lengths by 2 will be for the 40 meter band, and by 4, the 20 meter band. A transmitter may be operated on a fundamental wavelength of say 40 meters, and yet the antenna may be of 80 meter length. The transmitted note will be in the 40 meter band, but as a harmonic of the antenna.

### The "Zepp" Antenna

Figure 33 illustrates the Zepp Antenna. It is well known among amateurs

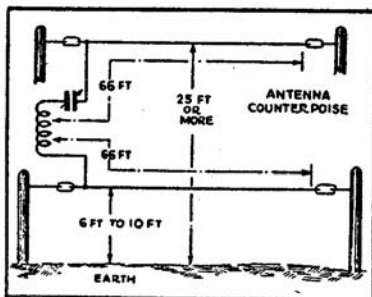

Fig. 36.

and is one of the most popular types. It is a non-directional type of antenna and works well on any band.

The "flat top" should be as high as possible. An angle of 90 degrees should be made between the antenna and feeders for a distance of at least one-third of the total feeder length. The "spacers" between the feeders can be small wooden sticks,  $\frac{1}{2}$ " x  $\frac{1}{2}$ " x 12". Pine, which has previously been boiled in paraffin, is preferred. Glazed Porcelain or Isolantite would serve most excellently. On each end

a slit of one inch is cut, so that the feeder wire will fit tightly. To prevent the "spacers" from slipping, a small nail may be driven in the end after the wire is placed in the slit.

The Single Wire Feed antenna is shown in Figure 34. This system is used mainly on the T. N. T. (tuned plate, fixed tuner grid) circuit and similar circuits.

Cut the antenna to length and then double it. Mark the wire at this point. From here measure exactly 18 feet and attach the feeder. It should be well fastened and made secure, or it will change frequency if moved.

Figure 35 shows one of the current feed systems. It is a well balanced antenna and is easily erected. The "spacers" are the same as described in Figure 33. An angle of 90 degrees must also be kept between the "flat top" and the feeder wires.

### Counterpoise System

The Antenna-Counterpoise system, Figure 36, is another great favorite, especially with those who live in crowded cities. The wires do not have to run in a straight line but are attached to the antenna tank and stretched as far as the wire will go.

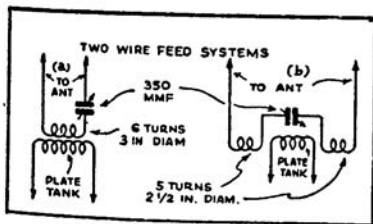

Fig. 37.

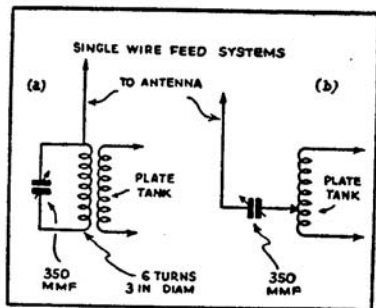

Fig. 38.

One wire should run fairly close to the ground. The other may go in any direction that is convenient.

### Current Versus Voltage Feed

There are two methods of coupling antennas to the transmitter. They are Current Feed and Voltage Feed Systems.

Figure 37 illustrates Current Feed coupling. (a) uses a single coil and works on any antenna except the single wire voltage feed antenna. Figure 37 (b) is the best known hookup and is recommended by most amateurs. This method of coupling requires a rather large space and sometimes cannot be installed for this reason.

Figure 38 illustrates two kinds of Voltage Feed coupling. These couplings are to be used on single wire feed systems only. (a) is the best type and will insure protection against illegal coupling. Both kinds may be used with the T. N. T. circuit

and other similar circuits. (b) is a common type but is very dangerous. A very good variable condenser must be used in the antenna circuit to prevent short circuit. *Direct coupling between the antenna and the transmitter is illegal in the United States.* (This does not apply to Hertzian antennas.)

### Antenna Coils

The antenna coils may be made from  $\frac{1}{4}$ " copper tubing or from No. 12 wire wound on a cardboard tube. Old copper tubing may be purchased very cheaply at any store that has

electric refrigerator repair service. The tubing can be easily cleaned by mixing a solution of washing soda and water. One heaped tablespoonful of washing soda to one quart of lukewarm water is about right. The solution does not have to be exact because it will not harm the tubing and will remove the dirt and corrosion effectively. A piece of steel wool should be rubbed on the tubing so as to remove any dirt that has not been removed by the solution. The tubing should be cleaned vigorously until it is clean and shiny. A coat of clear Duco lacquer is then applied.

### \*HELPFUL ANTENNA KINKS

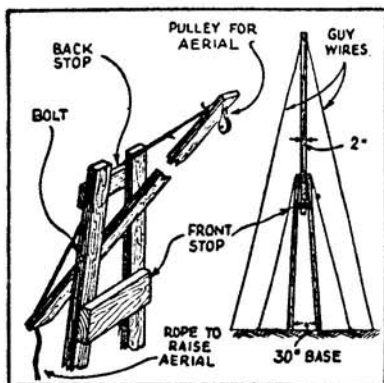

### "ONE-MAN" AERIAL MAST

Here is an idea for a "one-man" aerial mast. 1 erected one 50 ft. high. Take two pieces 2 x 3 in. and spread one end about 30 in. and the other 2 in., and nail these in position with 1 x 2 in. board. Next drill a hole about 6 in. from the top. The top piece is usually a 24 ft., 2 x 2 in. piece.

— C. R. Vogler.

\*Courtesy SHORT WAVE CRAFT.

### LEAD-IN INSULATION

By removing the small glass panes from the top of a window and replacing them with bakelite panels, it is possible to bring the lead-ins through the unit without necessity of drilling holes through the glass. The panels are fastened into the window sash exactly the same as the glass panes were fastened.

— Harold J. Clark.

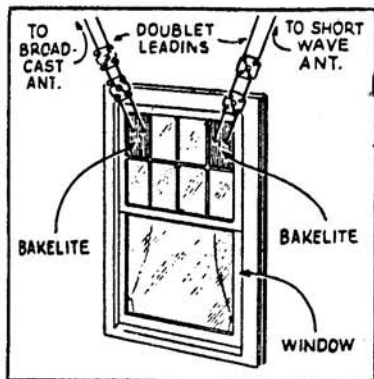

# GLOSSARY

## Of Technical Terms Used In This Book

- ALL-WAVE SET** — A radio set capable of tuning in stations operating on wavelengths from 10 to 2100 meters.
- BROADCAST SET** — A radio set which can tune in stations operating on wavelengths between 200 and 500 meters.
- DIPOLE or DOUBLET ANTENNA** — An antenna consisting of two elevated conductors of substantially equal length with the signal delivered from the center.
- ELECTROMAGNETIC WAVES** — Waves in space resulting from the radiation of electrical energy. For example, radio waves.
- ELECTROMAGNETIC FIELD** — The magnetizing force which always surrounds and accompanies electromagnetic waves.
- FEEDER** — That portion of an antenna system which connects the horizontal wire either with the receiver or transmitter. For example, the lead-in wire.
- FUNDAMENTAL FREQUENCY** — The basic frequency (number of complete vibrations or oscillations) of a periodic wave train or quantity.
- HARMONIC FREQUENCY** — An integral multiple of a fundamental frequency. For example, 2000 cycles per second is the second harmonic of the fundamental 1000; 3000 the third harmonic, etc.
- HERTZIAN ANTENNA** — An antenna system which is not grounded in any manner. For example, a double antenna.
- HIGH IMPEDANCE LINE** — A conductor or system of conductors offering considerable resistance to the flow of alternating current, especially radio frequency currents.
- INDOOR AERIAL** — A wire, loop of wire, metal plate or metallic tape contained in a room and connected at one end to the aerial post of a radio receiver.
- KILOCYCLE** — A kilocycle, when used as a unit of frequency is a thousand cycles per second. (See *Wavelength and Frequency*.)
- KILOWATT** — A kilowatt is equivalent to 1000 Watts, a watt being a unit of power.
- MARCONI ANTENNA** — An antenna system one end of which is always grounded. For example, the inverted "L" antenna (grounded through receiver).
- NATURAL PERIOD OF RESONANCE OF ANTENNA** — The lowest resonant frequency of an antenna without added inductance or capacity.
- RADIO FREQUENCY CURRENT** — Alternating current which changes its direction of flow at a rate greater than ten thousand times (or cycles) per second.
- ANTENNA RESONANCE** — A con-



dition where the natural frequency of the antenna matches or has been made to match the incoming frequency of the signal.

**SHORT-WAVE SET** — A radio set capable of receiving stations operating on wavelengths between 10 and 200 meters.

**R.F. TRANSFORMER** — A device consisting of two separate windings on a hollow form permitting R.F. currents in one winding to induce currents of a similar nature in the other winding.

**TRANSMISSION LINE** — That part of an antenna system which connects

the horizontal wire or wires to the receiver or transmitter. For example, feeders or lead-in wires.

**WAVELENGTH AND FREQUENCY** — A wavelength is the distance traveled in one period of cycle by a periodic disturbance. It is the distance between corresponding phases of two consecutive waves of a wave train. *Frequency* is the number of cycles per second of a period disturbance. For radio waves, wavelength (in meters) is equal to 300,000 divided by frequency (in kilocycles); where 300,000 represents the velocity of the waves.

## \*HELPFUL ANTENNA KINKS

### NOVEL LIGHTNING ARRESTER

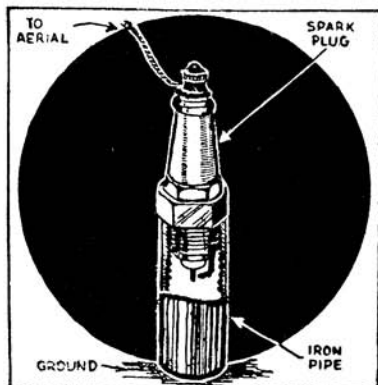

Excellent use for spark plugs. Thread or wedge into iron pipe driven into moist ground. Makes good lightning arrester.  
\*Courtesy SHORT WAVE CRAFT

### IMPROVED TRANSMISSION BLOCK

Made from the base of an old time bakelite socket. Makes an inexpensive, yet efficient transposition block. There are plenty of these sockets "floating" around.

— Frank Tapper.

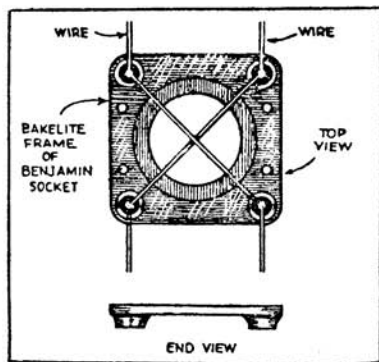

Here Are the Ten Titles of the Famous  
**GERNSBACK'S EDUCATIONAL LIBRARY:**



No. 1  
 How To Make  
 Four Doerle  
 Short Wave Sets

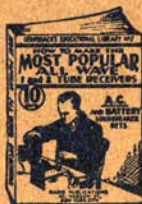

No. 2  
 How To Make The  
 Most Popular All-Wave  
 1- and 2-Tube Receivers



No. 3  
 Alternating  
 Current  
 for Beginners



No. 4  
 All  
 About  
 Aerials



No. 5  
 Beginners'  
 Radio  
 Dictionary



No. 6  
 How To Have  
 Fun With  
 Radio

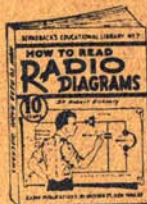

No. 7  
 How To Read  
 Radio  
 Diagrams



No. 8  
 Radio  
 For  
 Beginners



No. 9  
 Simple Electrical  
 Experiments

**10¢**

BOOKS ARE ALL UNIFORM  
 Every book in the GERNSBACK'S  
 EDUCATIONAL LIBRARY has  
 32 pages—with illustrations vary-  
 ing from 30 to 66 in number. Each  
 title volume contains over 15,000  
 words. POSITIVELY THE  
 GREATEST 10c VOLUME IN  
 RADIO BOOKS EVER OFFERED  
 TO THE PUBLIC.



No. 10  
 Television

Order books by number — remit by check, money order, cash  
 or unused U. S. Postage Stamps. Books are mailed POSTPAID.

**RADIO PUBLICATIONS, 25 WEST B'WAY, NEW YORK 7, N.**